



OWNERS AND SERVICE MANUAL

A.u.S. Spielgeräte GmbH

A-1210 Vienna Scheydgasse 48

SERVICE: +43 (0)1 271 66 00

FAX: +43 (0)1 271 66 00 75

E-MAIL: technik@aus.at

WEBSITE: www.aus.at

Table of Contents

Safety	3
Gameplay	4
Game Assembly / Setup	5 - 7
Split Base Assembly/Instructions	8 - 10
Programing and options	11 - 13
Error Codes	14
Game Operational Tests	15
Maintenance	16 - 18
Trouble Shooting	19 - 24
Assemblies	25 - 28
LED light kit install	29 - 34
Warranty	35

IF YOUR ICE SURFACE APPEARS TO BE WARPED:

The outer bolts that hold the dome to the cabinet needs to be slightly loosened to allow the ICE surface to expand.

If after loosening the bolts the surface has not flattened out please contact the service Department

SAFETY AND WARNINGS BEFORE YOU BEGIN

WARNING: WHEN INSTALLING THIS GAME, A GROUNDED A.C. RECEPTACLE MUST BE USED. FAILURE TO DO SO COULD RESULT IN INJURY TO YOURSELF OR OTHERS. FAILURE TO USE A GROUNDED RECEPTACLE COULD ALSO CAUSE IMPROPER GAME OPERATION, OR DAMAGE TO THE ELECTRONICS.

NOTE: THIS GAME IS INTENDED FOR INDOOR USE ONLY.

DO NOT DEFEAT OR REMOVE THE GROUNDING PRONG ON THE POWER CORD FOR THE SAME REASON AS GIVEN ABOVE. USING AN IMPROPERLY GROUNDED GAME COULD VOID YOUR WARRANTY.

HAVE A QUALIFIED ELECTRICIAN CHECK YOUR A.C. RECEPTACLE TO BE SURE THE GROUND IS FUNCTIONING PROPERLY.

THIS GAME IS DESIGNED TO DISSIPATE STATIC ELECTRICITY THROUGH THE GROUNDING PLANE OF THE GAME. IF THE A.C. GROUND DOES NOT WORK, THE GAME COULD DISCHARGE STATIC ELECTRICITY THROUGH THE GAME CIRCUITRY, WHICH COULD CAUSE DAMAGE.

THE POWER SUPPLY IS NOT VOLTAGE ADJUSTABLE. TO OPERATE THE GAME AT VOLTAGES OTHER THAN THOSE IT WAS DESIGNED FOR. PLEASE CONTACT OUR SERVICE DEPARTMENT FOR VOLTAGE CONVERSION INFORMATION.

WARNING

DO NOT remove any of the components on the main board (e.g. compact flash and EPROMS) while the game is powered on. This may cause permanent damage to the parts and the main board. Removing any main board component part while powered on will void the warranty.

ALWAYS REMOVE POWER TO THE GAME, BEFORE ATTEMPTING ANY SERVICE, UNLESS NEEDED FOR SPECIFIC TESTING. FAILURE TO OBSERVE THIS PRECAUTION COULD RESULT IN SERIOUS INJURY TO YOURSELF OR OTHERS.

THIS GAME IS NOT SUITABLE FOR INSTALLATION IN AN AREA WHERE A WATER JET COULD BE USED.

This appliance is not intended for use by persons (including children) with reduced physical, sensory or mental capabilities, or lack of experience and knowledge, unless they have been given supervision or instruction concerning use of the appliance by a person responsible for their safety. Children should be supervised to ensure that they do not play with the appliance.

The game's foot print is 60" x 30" x 54".

AC Power Information

The DC power supply provides the main AC power fuse. It is not user replaceable.

Replace the entire DC supply if failure is experienced.

4.5 amp at 110—120V. 2.5 amp at 200 –240V

SUPER CHEXX PRO™ GAME PLAY

The SUPER CHEXX PRO™ Hockey game has been designed to resemble “real” hockey action. The object of the game is to out-score your opponent before time runs out. Goals can be scored, with the game continuing, until the “last puck in play” mode begins. When the last puck in play is scored, the game ends.*

Example: If a score is 5-3, the last puck would result in a final score of 5-4 or 6-3.

*The exception to this rule occurs when a final puck would create a tie score.

Example: If the score is 2-1, the last puck might make the score 2-2. The game then automatically goes into a “Sudden Death Overtime” mode and a final tie-breaking puck is ejected. The game will end when the tie-breaking goal is scored.

The National Anthem, as well as the “Boo” sound and the “Ooh’s” and “Aah’s” add to the excitement of playing SUPER CHEXX PRO™. The “Boo” button can be used to eliminate the National Anthem or to “Boo” your opponent.

SUPER CHEXX PRO™ FEATURES

- **ALL NEW ELECTRONICS PLATFORM**

Uses state of the art technology manufactured at I.C.E.

- **OVERHEAD VIDEO JUMBOTRON SCOREBOARD WITH 5” LCD DISPLAY**

A video screen shows scores, shots on goal, running time clock, period display and live game animations.

- **UNIQUE SOUND EFFECTS**

Enhanced quality of sound with many new Rick Jeanneret recorded game calls. Along with synthesized organ chants and Home Team Goal Horns.

- **CENTER ICE FACE OFF**

Auto-ejecting puck eject assembly with improved design to reduce jams/one-sided face-offs.

- **NEW LIGHTING AND ILLUMINATION**

Red-Green-Blue LED Lighting and light show during anthem and goal celebrations. LED Lighting to illuminate the playing surface with brighter-white light. Red Goal Lights and Green Change of Period Lights under each goal.



GAME ASSEMBLY

These steps should be followed for initial installation as well as any time the game is dismantled and moved to a new location.

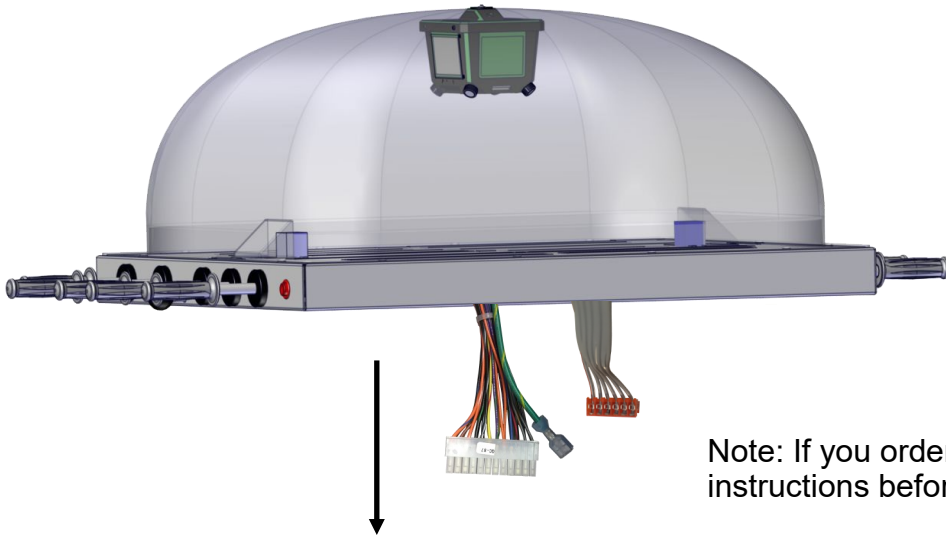

Note: If you ordered a split base, see split base instructions before proceeding.



Step 1:

Unbox the upper dome and base. Position the dome on to the base oriented with hinge side of cabinet opposite of the coin door or decal on the side of the base.

Pic C

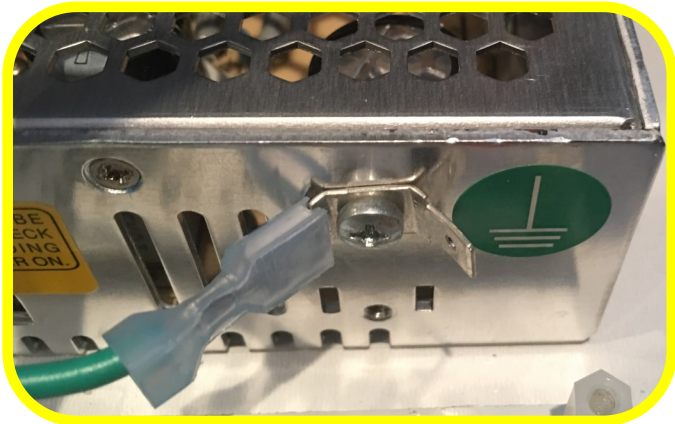

Step 2:

- Pic A - Plug the main harness into P3.
- Pic B - Plug the Jumbotron harness to P4.
- Pic C - Plug the ground wire onto the power supply.

Pic A

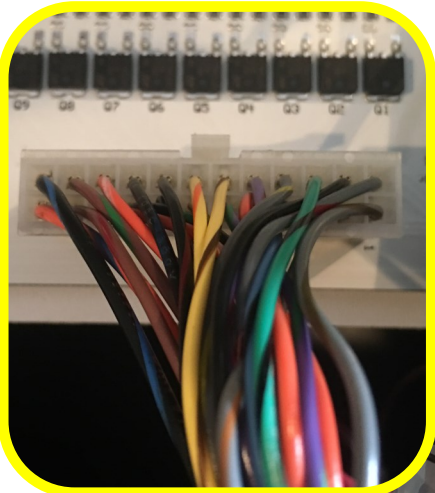

Pic B

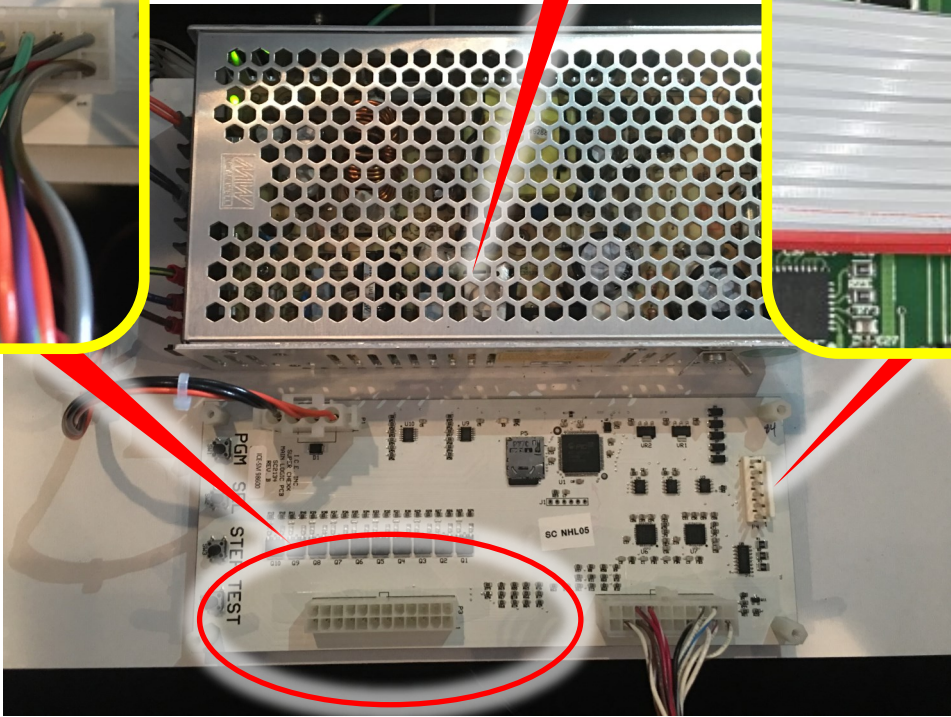

DO NOT TIGHTEN UNLESS ALL FOUR BOLTS ARE STARTED!



Step 3:

Secure the upper cabinet to the podium using four AA6404 5/16-18 x3" Allen bolts and four AA6067 washers.

Start the bolts by hand.

Make sure not to cross thread them as you turn.

Once all four are started, use the tool provided to tighten them.

Then plug the game into a 110 or 220 volt GROUNDED AC outlet. Open the coin door to access the power switch. On the home version, press the "POWER" button located at the side of the base.

Warning:

Failure to use a 3-prong grounded outlet will void your warranty and may cause harm to the game, yourself, and others.

Step 1: (How to Split the base)

The game must be ordered as a split base. Not all games manufactured are split base. If the game is fully assembled, separate the top assembly from the bottom and put the top assembly aside.

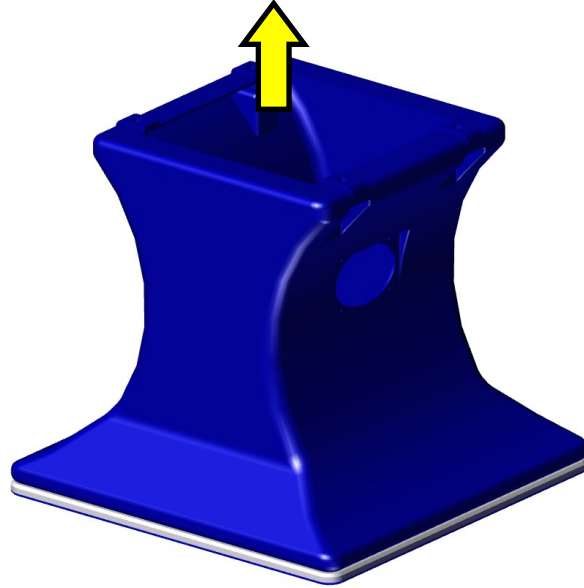
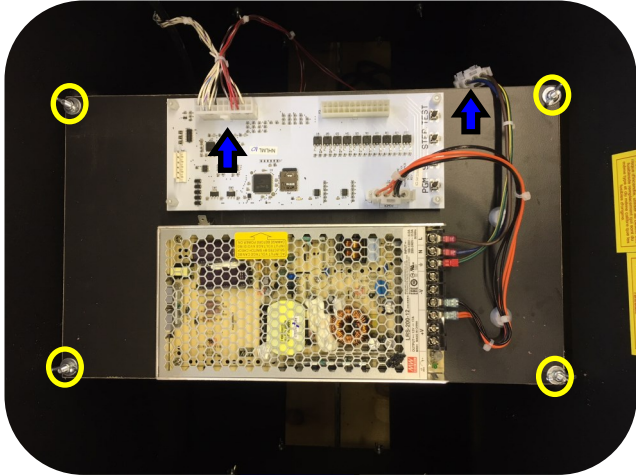
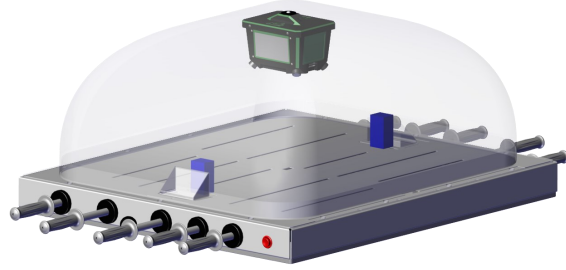

Step 2:

Disconnect the wire harnesses shown with the arrows. Then remove the four wing nuts circled and put PCB assembly aside.

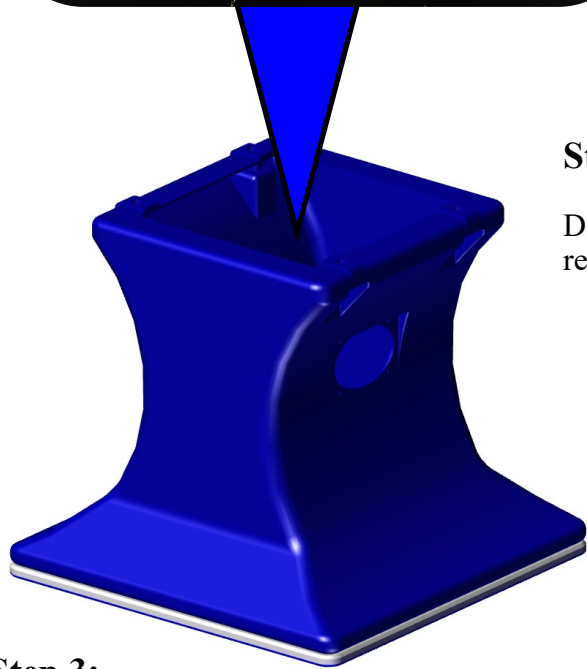

Step 3:

Unplug the wire connectors at each speaker.

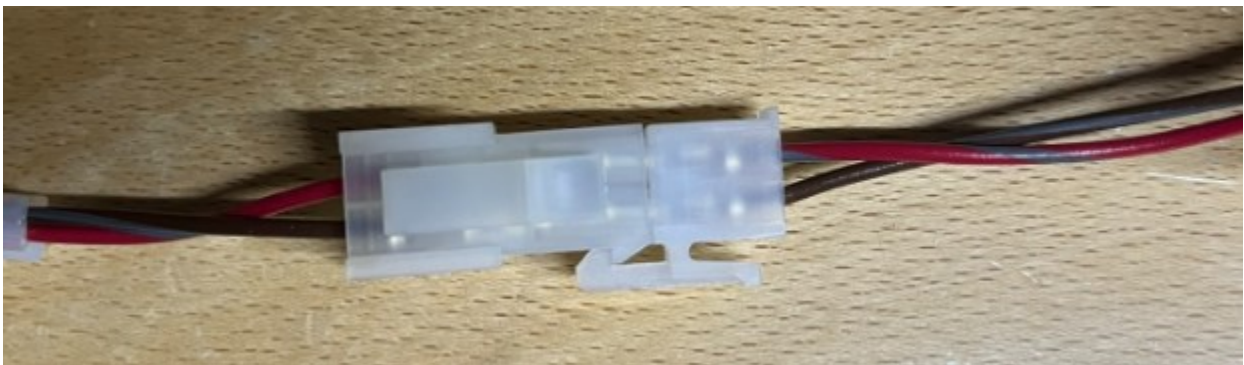

Step 4:

Disconnect the LED floor harness shown by the yellow arrow.

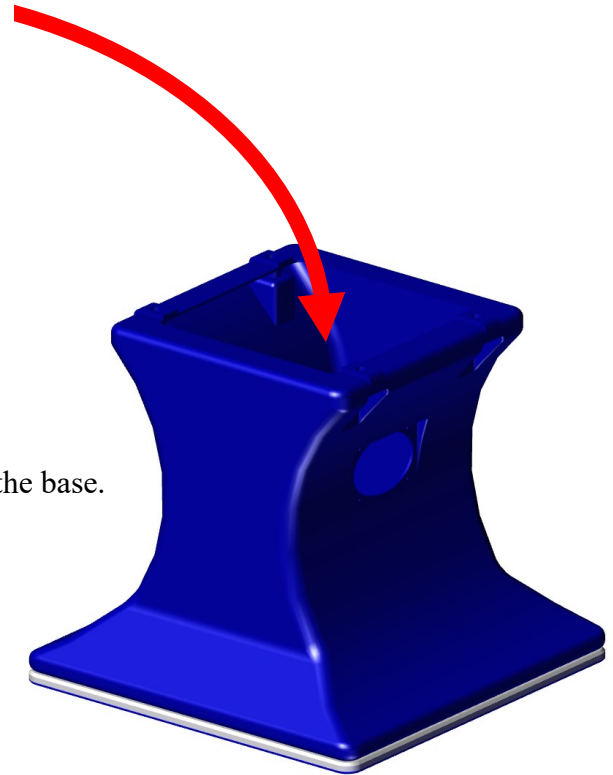
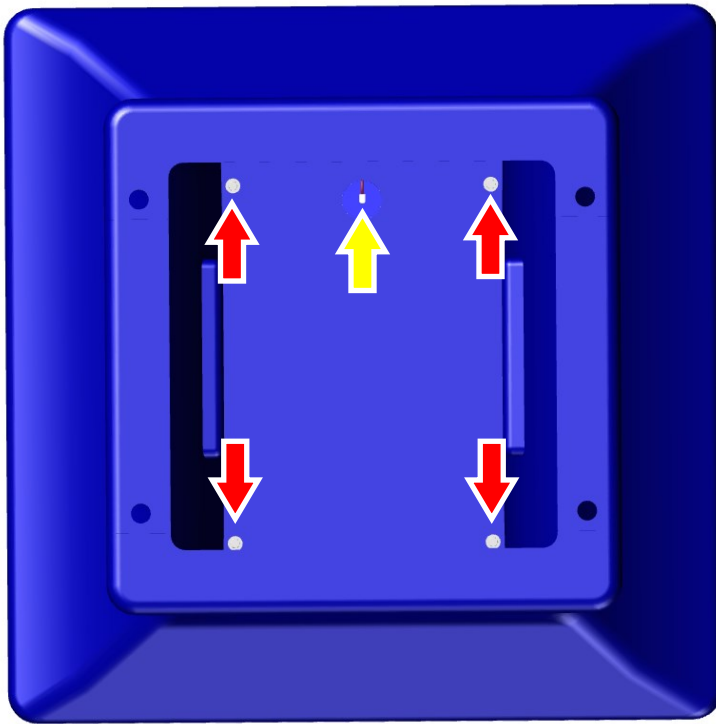

Step 5:

Remove the four bolts holding the floor LED assembly to the base.

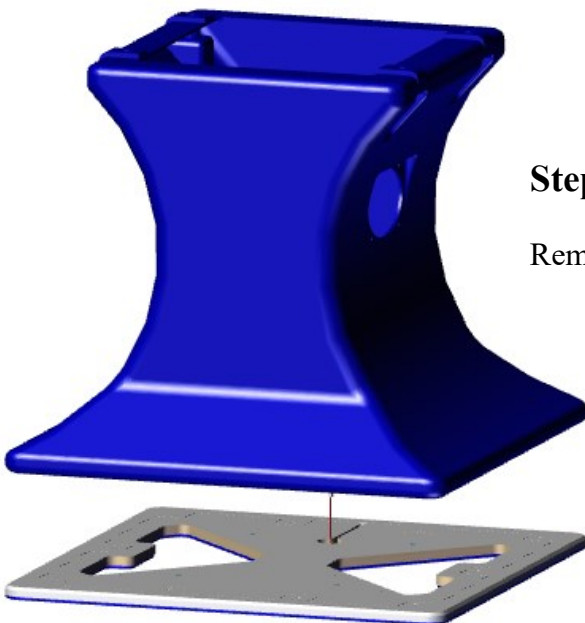

Step 6:

Remove the floor LED assembly.

Step 7:

If your game has a coin door installed, you will have to remove the coin door and the mounting frame. The mounting frame is held onto the base with 655 Square screws (blue arrows). Disconnect all wiring to the coin door, then remove the coin door first. See yellow arrows (8 total bolts). Then remove the mounting frame.



Step 8:

If your game has plates on each side you must remove the wing nuts that hold them to the cabinet. Remove both plates and put aside.

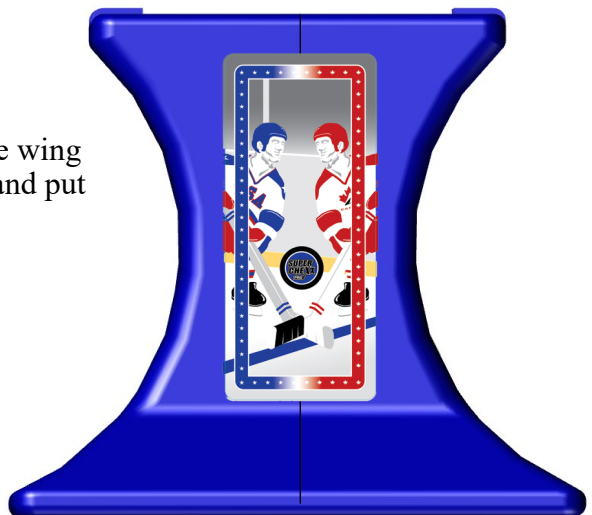
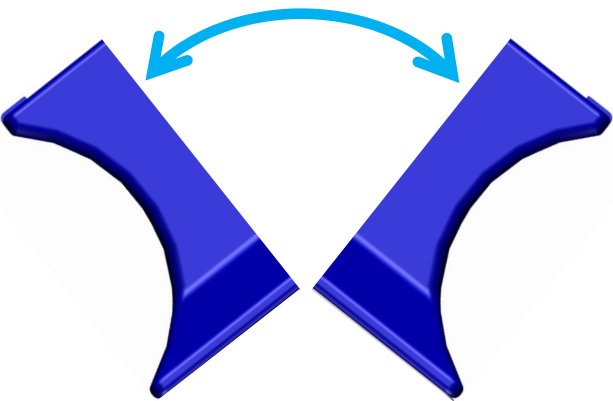

Step 9:

The cabinet is hinged at the bottom to allow it to split as shown. Re-assembly in reverse.



ALL NEW GAME MODES AVAILABLE!

Tournament Edition allows players to select exciting new ways to compete against each other. You can select best out of three games in player verses player mode or play the classic way, best score wins in three periods. Tournament mode allows either four players or eight players to compete to win the Super Chexx Pro Cup!

The boo buttons are used to navigate through the different screens. Tapping the boo button will select an option while holding the boo button down will select it. In coin-op mode, the different game modes can be charged at different rates. As the player selects the game mode, they will be prompted to insert more money if needed before they can start the game mode.



How To Enter Program Mode - Home Edition

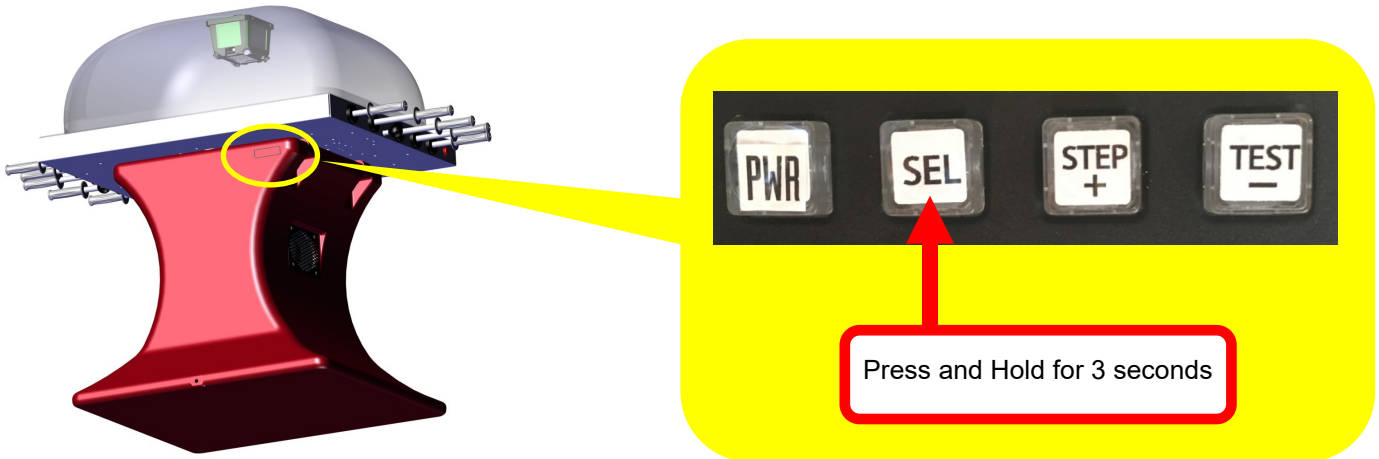

How To Enter Program Mode - Coin-op Edition

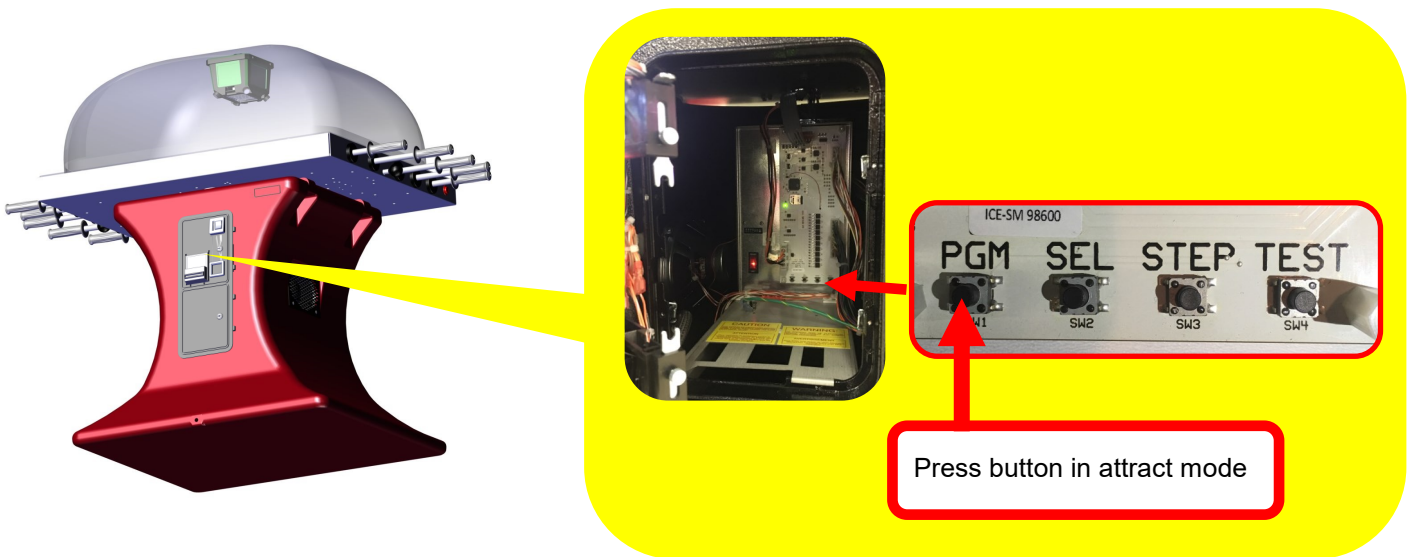

Once in program mode, the jumbo screen will show the game option and current value.

- Press the “SEL” button to go to the next option.
- Press “Step” and “TEST” to change the option value.
- Exit program mode the same way you entered the mode.

COIN OP:

Option	Min	Max	Default
Game volume	0	10	5
Attract volume	0	10	3
Cost per play (in coin 1's)	0	8	2
Coin #2 value (in coin 1's)	0	8	1
Minutes per period (30 second increments)	1	10	2
Last chance puck	0	1	1
Anthem select	See Table 2		United States
Tickets per play	0 (off)	20	0
Ticket multiplier	1	2	1
Video attract interval (s) (2 second increments)	2	30	4
Attract audio interval (1 video increments)	1	180	4
Team select (Home)	See Table 1		Red
Team select (Away)	See Table 1		Blue
Underlighting color	See Table 4		0
Exchange Color (swap goal video teams)	0	1	0
Anthem LED colors (spot light color pattern)	See Table 3		Red/Blue
Goal light show	Off	On	On
Credit discount	0	20	0
Discount value	0	20	0
Anthem enable	Off	On	On
Reset defaults	0	1	0

COIN OP:

Option	Min	Max	Default
Flip Home/Visitor	0	1	1
Boo Sounds Only	0	1	0
Tournament Enable	0	1	1
Cost per 3v1	0	20	4
Cost per 4p Tournament	0	20	6
Cost per 8P Tournament	0	20	8
Team #1	See Table 1		
Team #2	See Table 1		
Team #3	See Table 1		
Team #4	See Table 1		
Team #5	See Table 1		
Team #6	See Table 1		
Team #7	See Table 1		
Team #8	See Table 1		
Reset defaults	0	1	0

HOME:

Option	Min	Max	Default
Game volume	0	10	5
Attract volume	0	10	3
Minutes per period (30 second increments)	1	10	2
Last chance puck	0	1	1
Anthem select	See Table 2		United States
Video attract interval (s) (2 second increments)	2	30	4
Attract audio interval (1 video increments)	1	180	4
Team select (Home)	See Table 1		Red
Team select (Away)	See Table 1		Blue
Underlighting color	See Table 4		0
Exchange Color (swap goal video teams)	0	1	0
Anthem LED colors (spot light color pattern)	See Table 3		Red/Blue

HOME:

Option	Min	Max	Default
Goal light show	Off	On	On
Anthem enable	Off	On	On
Flip Home/Visitor	0	1	1
Boo Sounds Only	0	1	0
Tournament Enable	0	1	1
Team #1	See Table 1		
Team #2	See Table 1		
Team #3	See Table 1		
Team #4	See Table 1		
Team #5	See Table 1		
Team #6	See Table 1		
Team #7	See Table 1		
Team #8	See Table 1		
Reset defaults	0	1	0

TABLE 1

	Team Name	
1	Red	BOTH
2	Blue	
3	Zambonis	S C M L O N L Y
4	Checkers	
5	Rink Rats	
6	Bench Warmers	
7	Barn Burners	
8	Hat Tricks	
9	USA	
10	Canada	
11	CCP	

12	Anaheim Ducks	N H L
13	Arizona Coyotes	
14	Boston Bruins	
15	Buffalo Sabres	
16	Calgary Flames	
17	Carolina Hurricanes	
18	Chicago Blackhawks	
19	Colorado Avalanche	
20	Columbus Blue Jackets	
21	Dallas Stars	
22	Detroit Red Wings	
23	Edmonton Oilers	
24	Florida Panthers	
25	Los Angeles Kings	
26	Minnesota Wild	
27	Montreal Canadiens	
28	Nashville Predators	

29	New Jersey Devils	N H L
30	New York Islanders	
31	New York Rangers	
32	Ottawa Senators	
33	Philadelphia Flyers	
34	Pittsburgh Penguins	
35	San Jose Sharks	
36	St. Louis Blues	
37	Tampa Bay Lightning	
38	Toronto Maple Leafs	
39	Vancouver Canucks	
40	Vegas Golden Knights	
41	Washington Capitals	
42	Winnipeg Jets	
43	Quebec Nordiques	
44	Hartford Whalers	
45	Minnesota Northstars	

46	Not Used	BOTH
----	----------	------

TABLE 2

	ANTHEMS
1	UNITED STATES
2	CANADA (ENGLISH)
3	CANADA (FRENCH)
4	RUSSIA
5	UNITED KINGDOM
6	TURKEY
7	FINLAND
8	GERMANY
9	Not Used

TABLE 4

	Underlighting Color
1	Off
2	Red
3	Green
4	Blue
5	Light Blue
6	Yellow
7	Pink
8	Cycle all colors

TABLE 3

	ANTHEM LED colors
1	BLUE/GREEN
2	RED/GREEN
3	RED/BLUE
4	BLUE
5	GREEN
6	RED

Super Chexx Pro error codes

SC2134X - Main logic board (version *ML30 and newer)

The errors are displayed on this board using the green LED located at D3.

ERROR	DESCRIPTION	POSSIBLE CAUSES
LED flashes 2x, pause, repeats	SD Card not detected	No SD card inserted Open/shorted connection between socket and MCU Damaged SD card
LED flashes 4x, pause, repeats	Number of files on SD card does not match number reported from SD card	SD card missing files Old version SD card inserted (1.4 and earlier) Fxxx file missing

SC2132X – Jumbotron LCD display (version SCLCD34 and newer)

The errors are displayed in the lower right corner of the jumbotron scoreboard screen in **RED**. Errors are specific to each side.

ERROR	DESCRIPTION	POSSIBLE CAUSES
1	SD Card failed to respond to the first CMD8 request	No SD card inserted Open/shorted connection between socket and MCU Damaged SD card
2	SD Card failed to respond to the ACMD41 command.	Open/shorted connection between socket and MCU Damaged SD card
3	SD Card missing master boot record.	Bad SD Card sector in critical location Incorrect format (not FAT32)
4	SD Card has Less than 30 Video files.	Bad SD Card Failure during copy process.
5	Number of files on SD card does not match number reported from SD card	SD card missing files Old version SD card inserted (1.4 and earlier) Fxxx file missing

GAME OPERATION - TEST

1. Before starting a game, check to see that all players rotate smoothly and that all rods move in and out freely.

NOTE: THE GEAR BOXES REQUIRE 10 - 20 GAMES TO FULLY BREAK IN. SLIGHT RESISTANCE WHEN ROTATING THE PLAYERS ON A NEW GAME IS NORMAL.

2. Insert the proper number of coins to start game or press BOO if home edition.. The Anthem will begin to play and the video will show players lined up. Upon completion, the puck will eject from the ejector chute.
3. Shoot the puck in each net several times to ensure proper operation of the ejector.
3. Each time the puck enters the net; the score indicators on both sides of the scoreboard should indicate the goal scored. Continue scoring until the game ends, checking the score indicators for proper operation. Check to see that the score indicators on both sides of the scoreboard are working correctly.
4. Restart the game. Press the Boo/Start button to ensure the Anthem is bypassed. The puck should eject.
5. After the puck ejects, press the Boo/Start buttons on both ends of the game to ensure the "Boo" sound is heard.
6. Run the puck through each goal crease. The "Oh" sound should be heard as the puck passes through the crease. Note that a shot on a goal has been registered.

NOTE ABOUT BOO'S. You can now enable boo only in your game options.

The rules for a "boo" sound to be played works like this. When the game plays either the organ or chant sounds, it takes precedent over the boo button. These sounds are played every 20 seconds, and each last between 6-10 seconds. This fills the game up with action but limits the opportunities to play the "boo" sounds.

The "boo" sound block is two sound blocks (Boo's and Cheer's). They are alternated throughout the game (boo then cheer) as each press is played, and to enhance the gameplay there are different sayings being played. The table of sounds is below.

050	where's the referee	051	BOO / Get him out of here
052	that just missed his head	053	BOO 1
054	what an awful call	055	BOO 2
056	took the legs right out from under him	057	BOO 3
058	And the fans are letting him have it	059	blank
060	great hit!!!	061	CHEERS / BANGS
062	what a hit	063	CHEERS
064	laid him out right along the boards	065	CHEERS / WHISTLES
066	OH, he leveled him	067	CHEERS
068	D-FENSE	069	blank

MAINTENANCE

All parts in the SUPER CHEXX PRO™ Hockey Game have been manufactured to the highest standards possible. The following maintenance should be performed as recommended to assure optimal performance and longevity of the game.

WARNING: THIS GAME DOES NOT REQUIRE ANY LUBRICATION. USE OF ANY OILS OR GREASE MAY VOID YOUR WARRANTY.

Most mechanical maintenance jobs, when required, will necessitate removal of the dome and / or ice surface. In all cases, when the ice surface must be removed, follow the ice surface removal procedure as given.

PARTS KIT

Included in the spare parts kit, is a wire cable with loop & hooks. This is used to hold the dome open when tilted back to service the game.

In the event the goalies are removed, extra cotter pins are provided if the original cotter pins are damaged or lost.

PUCK

Inspect the puck for large gashes, which may impede a smooth rolling action down the puck ramps. Replace if necessary.

PUCK RAMPS

Periodically check the puck ramps for dirt accumulation and / or other objects or materials that may cause the puck action to slow down. To clean the ramps, remove the goalies. Slide all players to center ice (this saves time, as all the players and ice surface do not have to be removed). Bend up the ice on either end and remove the nets. Clean out the tracks and reassemble.

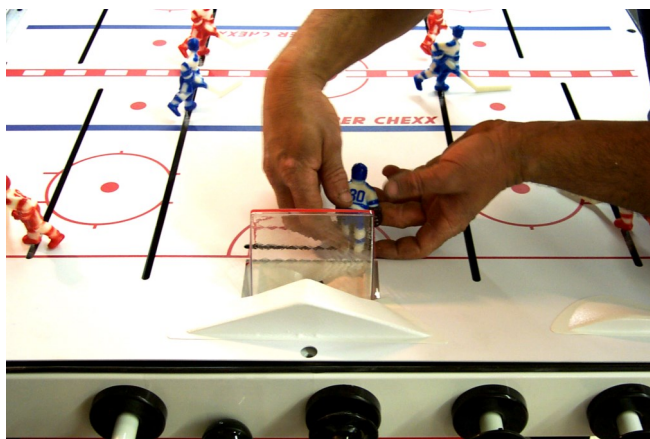

COIN MECHANISMS

Mechanisms should be cleaned and adjusted when necessary. Follow the manufacturer's instructions on adjustment and maintenance.

PLAYER WASHERS

These washers, located over each gearbox, serve to keep the players shafts in place in their gearboxes.

Extreme care should be exercised when pulling out or pushing in players because a washer that falls into a track can be bothersome to remove. To help eliminate this problem, push all the rods all the way in, and pull the player straight out. When pushing a player back in, be sure the gearbox is lined up with the shafts. If not, slowly rotate the rod while pushing down on the player.

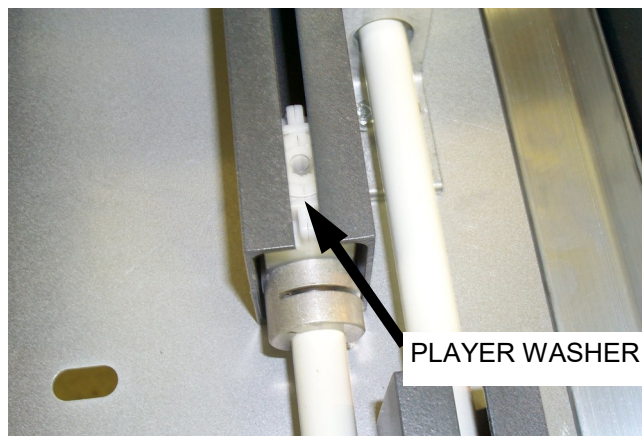

MAINTENANCE



VIEW OF PLAYER AFTER INSTALLATION

NOTE: WASHERS SHOULD BE REPLACED WHEN WORN TO THE POINT THAT THEY CAN NO LONGER HOLD THE PLAYERS IN. AFTER PLAYERS ARE INSERTED, PULL UP GENTLY TO TEST THE STRENGTH OF THE WASHERS.

SOUND EFFECTS

Periodically test the sound effects, sensors, and the “Boo” button to ensure the proper functions. Test for National Anthem by pass.

ICE SURFACE

The ice surface should be cleaned as needed, using Windex™, Fantastic™, or a comparable product. Apply liberally to a lint-free cloth, wipe surface thoroughly, and let dry. For a “faster” ice surface, dust lightly with Pledge™ and let dry.

DOMES

The Lexan dome should be cleaned as needed, using a furniture polish type of cleaner. Apply to a lint-free cloth and wipe dome thoroughly.

NOTE: PLEDGE™ IS RECOMMENDED. ALWAYS TEST THE CLEANER YOU INTEND TO USE ALONG THE FLANGE TO MAKE SURE THE CLEANER WILL NOT HARM THE DOME FINISH. TO REMOVE SCRATCHES, A SPECIAL SCRATCH REMOVER FORMULATED FOR LEXAN SHOULD BE OBTAINED.

PLAYERS

Periodically inspect the players for appearance or possible damage. Replace when necessary.

EJECTOR MECHANISM

Periodically test the mechanism by scoring goal and observing puck ejection. If puck fails to eject, does not clear ice surface, the mechanism is not working correctly. Open the dome and remove the ice surface.

**NOTE:
BE CAREFUL NOT TO LOSE THE FLAT WASHERS.**

Start the game and observe operation. Check for foreign particles under the ejector arm. The entire bracket assembly can be repositioned to correct improper ejection

in any direction. Loosen the 2 mounting screws and re-position as necessary. Be sure all parts work freely.

Check by pushing the solenoid plunger only, to see that the ejector lifts up about 3/8” from the cabinet bottom. If less movement is noted, be sure that the ejector is not hitting any of the side chute areas or has become bent through failure of another part.

Excessive random angle ejections can be eliminated by centering the ejector in the vertical area of the chute. (An improperly positioned ice surface may also cause angled ejections) An ejector that sticks in the up or down position is due to either improper positioning, a broken spring or a damaged solenoid.

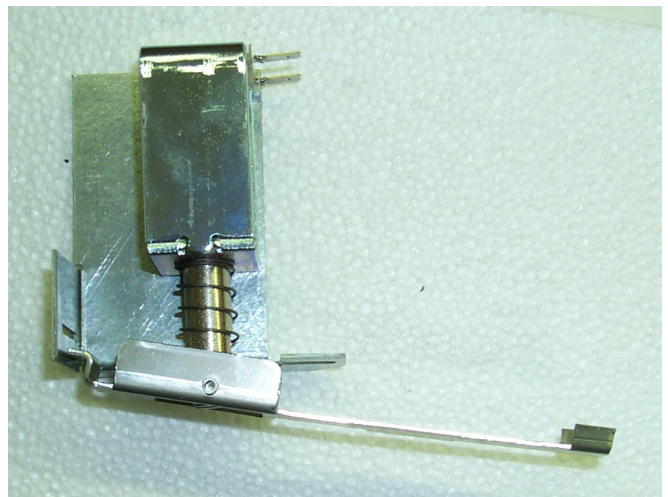
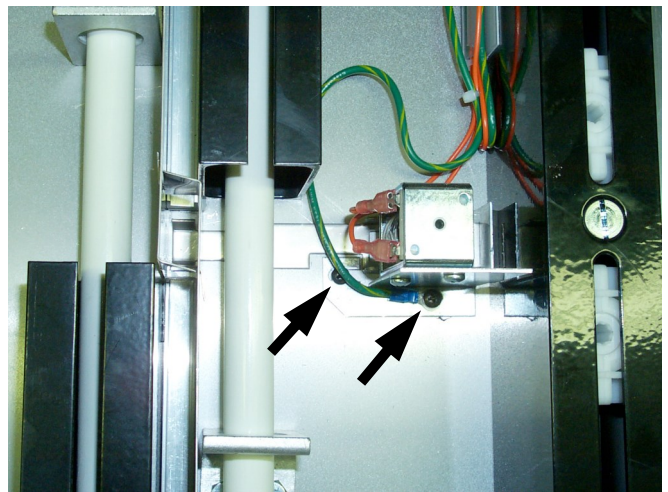

MAINTENANCE

GEARBOXES

Gearboxes should be inspected periodically to ensure smooth operation. Gearbox tracks should be kept as clean as possible. If a gearbox seems to rotate stiffly, first check to see that a rod collar is not pushed up tightly against it (this can happen if a grip comes off a rod and a gearbox hits a solid object, usually on defensemen). Back off a collar from a gearbox by loosening, moving, and retightening.

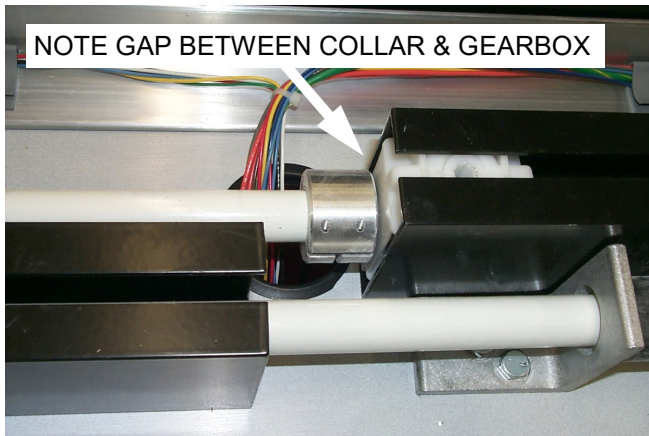

NOTE GEARBOXES ARE LUBRICATED FOR LIFE AND SHOULD NOT BE OILED OR GREASED.

ROD BEARINGS

Check once a year for excessive wear. Replace when necessary.

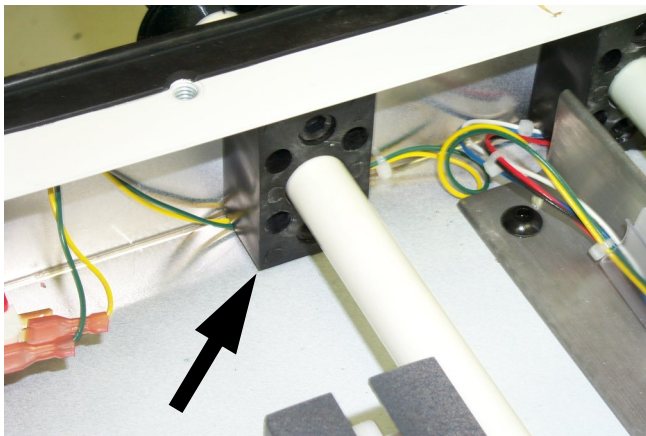

PUCK CHUTE

Clean periodically to ensure a good sliding surface. Check for cracks. Small cracks can be glued with a C/A



adhesive. Large cracks require changing the part.

GOALIE MECHANISMS

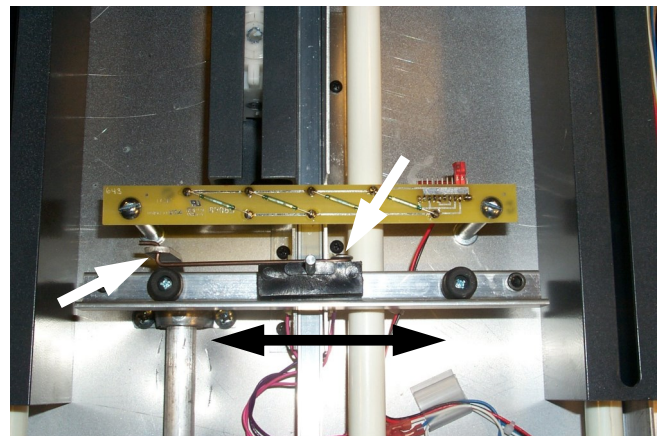

Check for smooth operation.

RODS

Check periodically for cracks and gouges. Replace if necessary. Clean Mineral Spirits or Paint Thinner. Do not allow cleaner to contact the Dome, as it will damage the Dome.

TRACKS

Check periodically. Clean by pushing a rag along the length of the track.

SENSORS

These should be tested periodically by moving the puck over the "Oh" sensors and through the score sensors. Test a suspect sensor by unplugging and testing with ohmmeter. Replace if necessary.

TROUBLESHOOTING AND REPAIR

PUCK WILL NOT EJECT

IF JUST ASSEMBLED OR MOVED:

Power off game.

Unlatch P3 harness from the main board. Using both hands, insert the harness evenly until a "Click" is heard.

Recheck for the solenoid for proper operation.

If still not working:

Open the dome and slide all of the players to the center ice can correct dirt in the puck ramps. Next, remove the goalies one at a time, bend up the ice surface and clean the ramps. Assemble in the reverse order. Use a flash light to see if you can see the puck stuck in the chute.

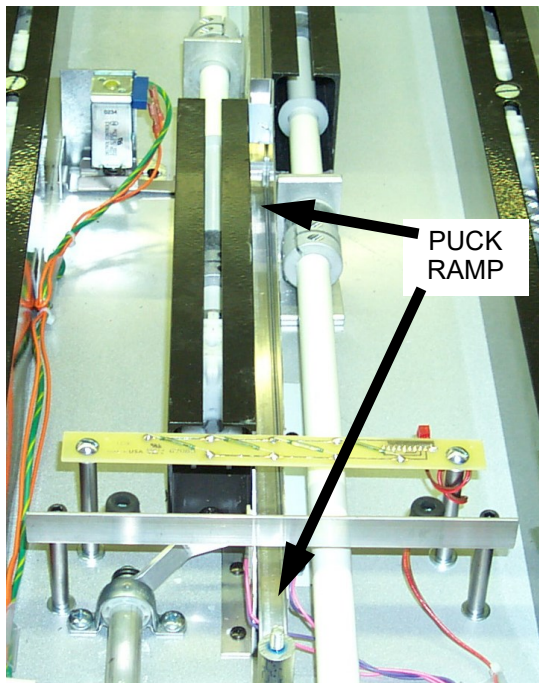

Still not working:

Turn the game off and unplug the unit from the wall.

Remove the 4 bolts holding the top to the base of the game

Balance the top of the game on the base and something of a similar height so you can access the main board.



Locate the P3 connection on the main board, squeeze the locking tab on the top of the connector and pull away from the circuit board to unplug the connector from the board.

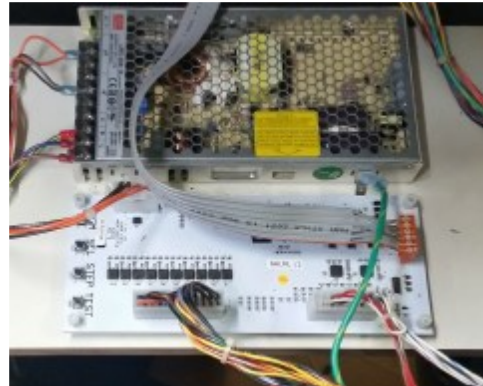

Locate the orange/blue trace wire and the black/blue trace wire, these wires are connected to the eject solenoid.



Locate two metal paper clips and bend them so they are straight.



Insert one paper clip into the orange/blue wire and the

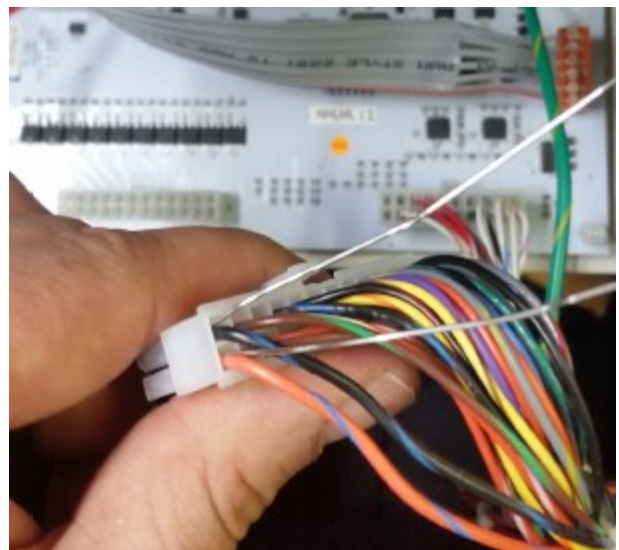

TROUBLESHOOTING AND REPAIR

Take a 9 volt battery and touch the ends of the metal paper clips to the terminals of the battery, each time you do you should hear the solenoid energize.

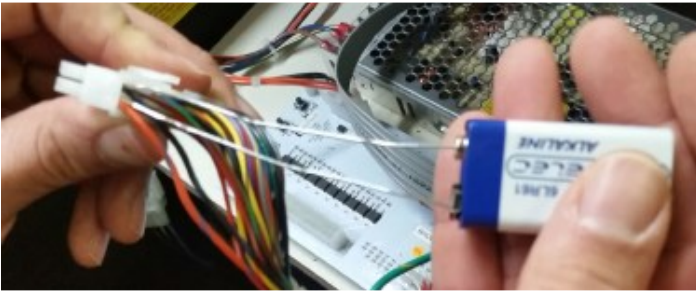

Replace solenoid if you do not hear or see the solenoid energize.

PUCK TAKES TWO OR THREE TIMES TO EJECT

1. A puck hitting the ice surface can be corrected by first making sure the ice surface is in place and centered. Moisture can cause plastic to expand and contract. Tighten bolts only until they are snug and do not over tighten them.

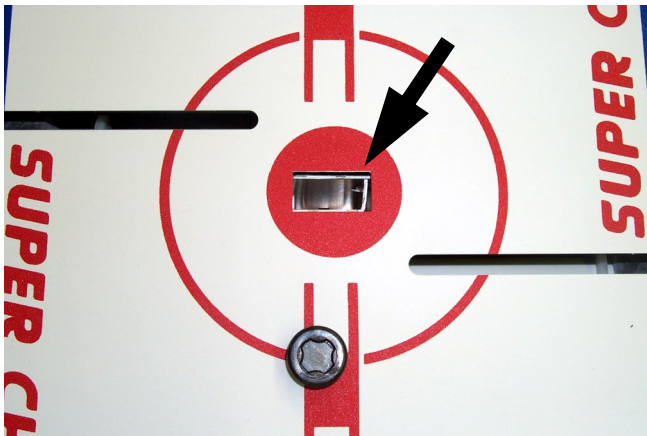

2. To determine if the ejector is misaligned, first remove the ice surface and then start the game. Look straight down the ejector chute and observe how the puck ejects. If the puck consistently hits one side of the chute, the ejector should be adjusted. Loosen the 2 screws that mount the solenoid assembly to the cabinet. Re-position the assembly so that the cup where the puck sits is centered into the vertical area of the chute.

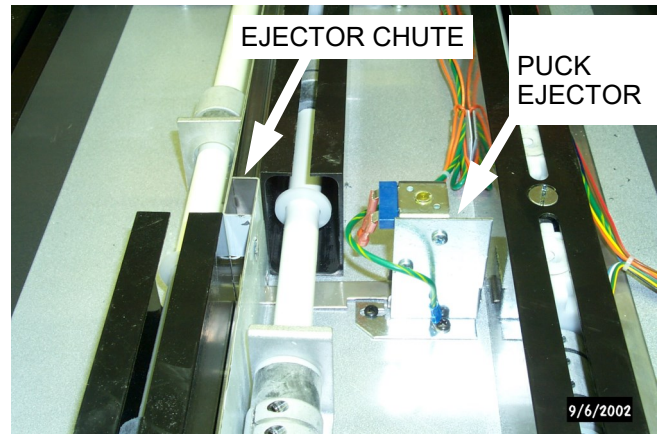

TROUBLESHOOTING AND REPAIR

GEARBOX IS DIFFICULT TO TURN

1. A gearbox-coupling collar may have been forced against a gearbox causing uneven or difficult turning. The usual cause for this is a handle grip coming off a rod and allowing the gearbox to hit either another gearbox or a cabinet end. To repair, simply loosen the collar and back it away from the gearbox between 1/32" and 1/16". Retighten.
2. Gear teeth being stripped out will generally cause binding at certain points of rotation. This situation should not occur until many games have been played. However, to check for bad gears, first remove the gearbox from the game. Loosen the gearbox collar and slide out the gearbox. If teeth on gears are worn out, replace the gearbox.
3. A worn gear bearing can cause a gearbox to work improperly. If you suspect a gear problem, first remove the gearbox from the game. If no problems are visible, disassemble the gearbox. If a worn bearing is found, replace the gearbox.

PLAYERS RUN INTO THE END OF THEIR SLOTS

1. A rod collar slipping may cause a player to hit the end of a slot in an ice surface. Open the game and rotate the rod until you can see the rod and gearbox touch, through the slot in the collar. If the rod and the gearbox do not touch, loosen the collar make sure the rod and gear box coupler touch, and retighten the gearbox. Be sure to leave 1/32" to 1/16" between the collar and the gearbox body.

PLAYER ROD & GEAR BOX SHAFT MUST MEET IN CENTER OF COLLAR SLOT

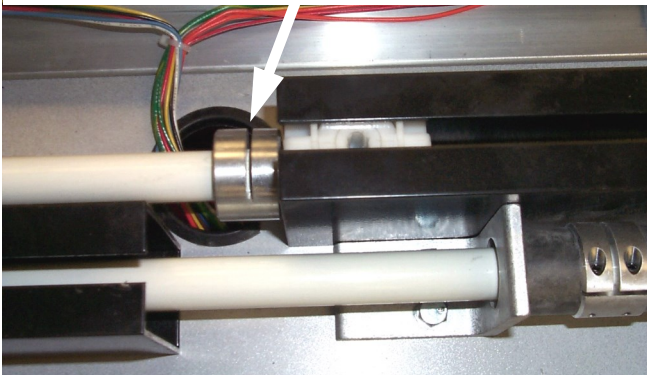

GAME LOSES PLAY SEQUENCE. GIVES FALSE SCORE, WILL NOT START WHEN MONEY IS INSERTED

1. Although game is protected against static electricity, an unusually large shock will cause the microprocessor to lose sequence. To correct the problem, turn off power and turn it back on to reset electronics.
2. A game plugged into an ungrounded outlet has no protection from static electricity. A large enough shock may destroy the IC chips. Electronic tests may be run to determine the fault. Repair as necessary.

COINS NOT REGISTERED CORRECTLY

1. A bad micro-switch may be a problem due to internal failure. Test with an ohmmeter. Replace if necessary.
2. Loose connections may cause money to be registered improperly. Check the connectors from the coin mechanisms, as well as the connectors on the main PC Board. Repair if necessary.

NO "OH" SOUNDS OR REPEATED "OH" SOUNDS

1. Short or open circuits in the harness or one of the reed switches on the "Oh" sensors are the most common problems. Repair as necessary.

SCORE IS NOT REGISTERED-NO CHEER

1. A bad Reed Switch may cause a goal not to register. Disconnect and test with an ohmmeter. Replace if defective.
2. A bad connection could be a problem. Check associated harnessing and connectors with an ohmmeter.

SCORE AND CHEERING KEEPS REPEATING FOR ONE TEAM WITH NO GOALS ACTUALLY BEING SCORED

1. A Reed Switch shorted to the cabinet will cause this problem. Usually an exposed wire touching the cabinet will be the cause of the problems.
2. A Reed Switch, always closed, can be tested by first disconnecting it from the board. Use an ohmmeter to see if the switch is always closed. If it is, replace the score Reed Switch.

TROUBLESHOOTING AND REPAIR

STATIC SOUNDS, REPEATED SOUNDS, STUDDERING, OR LOUD BEEPS INSTEAD OF AUDIO ARE HEARD.

1. The SDCARD possibly is corrupted. The game uses three identical SDCARDS. One is located on the main board and the other two are used in the display devices at the top of the game.
2. To see if the SDCARD is at fault, swap a card from the main board with one out of a display.
3. If the audio is good, you can also copy the files from that card onto a new SDCARD and replace the defective SDCARD. If the problem remains, contact ICE service to repair the main board.

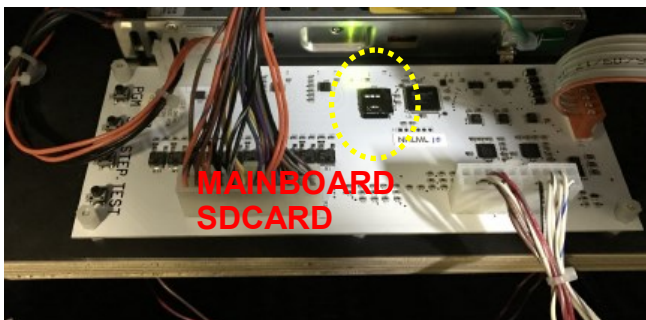
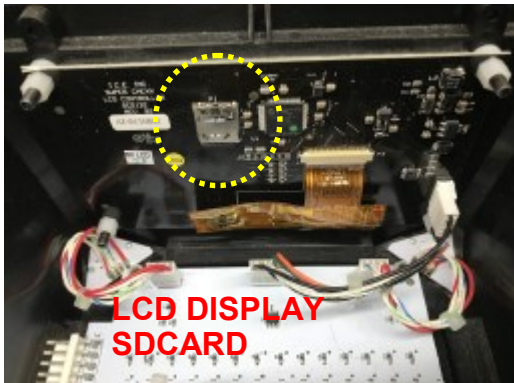

PLAYERS RUB ON THE SIDES OF THEIR SLOTS

1. On rare occasions a track may become bent, forcing the player to work improperly. If, when the ice surface is properly located, you can see the top of an aluminum track, the track must be bent. Use a large screwdriver or other suitable object, and gently pry in the desired direction to obtain clearance. Check for smooth operation.

NOTE: BE SURE NOT TO GOUGE THE SIDE OF THE CHANNEL WHEN PRYING. A RAG SHOULD BE WRAPPED AROUND YOUR SCREWDRIVER.

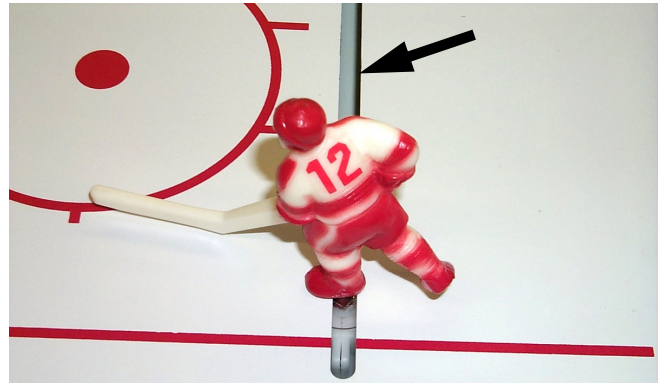

NOTE: ALUMINUM TRACK IS NOT VISIBLE IN PHOTO.

PUCK GOES UNDER STICK OR PLAYER SCRAPES ICE

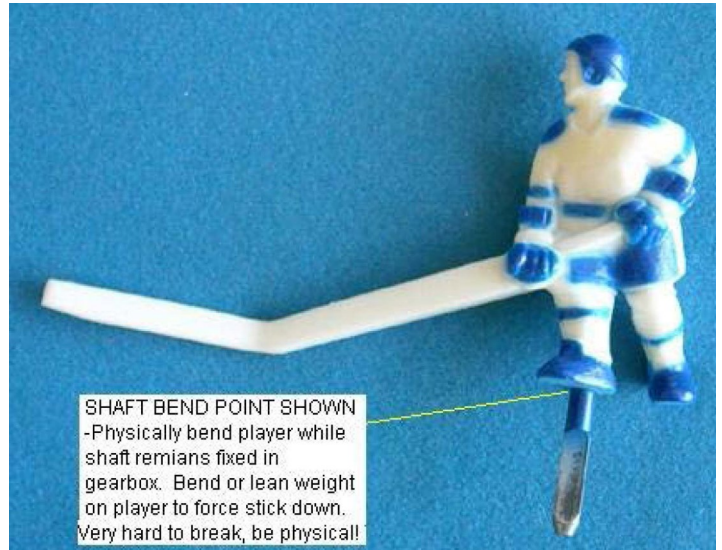

TOUCHING UP PLAYERS

Use paint or marker to touch up colors on men and spray with clear Lacquer. Krylon brand lacquer is recommended.

TROUBLESHOOTING AND REPAIR

TOP CABINET ASSEMBLY WITH ICE SURFACE & PLAYERS INSTALLED



PLAYER NUMBERING AND LAYOUT

	<u>18 Long</u>		12 Short
	6 Short		<u>4 Short</u>
30 Goalie	<u>14 Short</u>	14 Short	<u>30 Goalie</u>
	4 Short		<u>6 Short</u>
	<u>12 Short</u>		18 Long

TROUBLESHOOTING AND REPAIR

TOP CABINET ASSEMBLY WITH ICE SURFACE & PLAYERS REMOVED

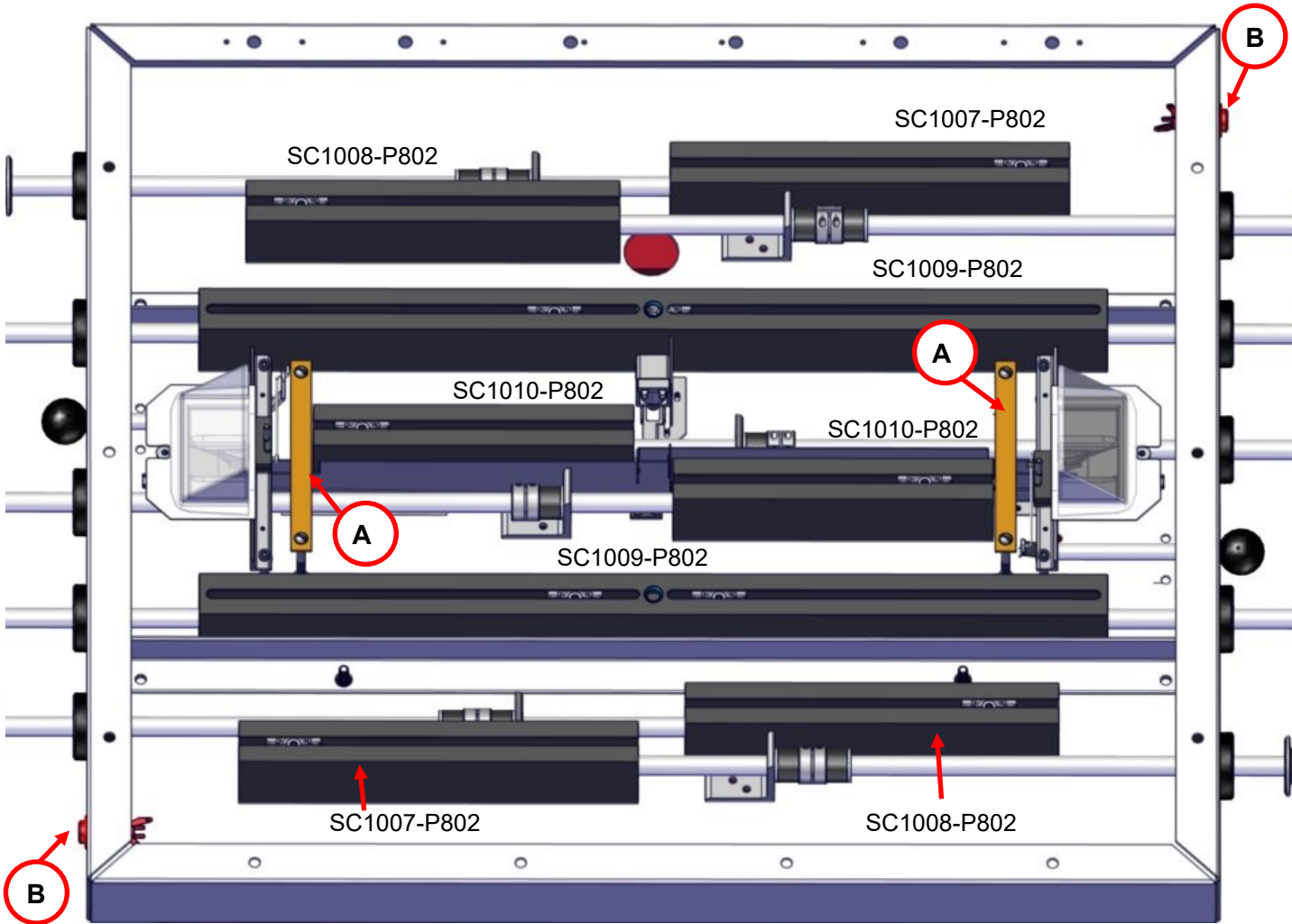

A Oh Sensor SC6706X



B Boo Button and switch EV2005

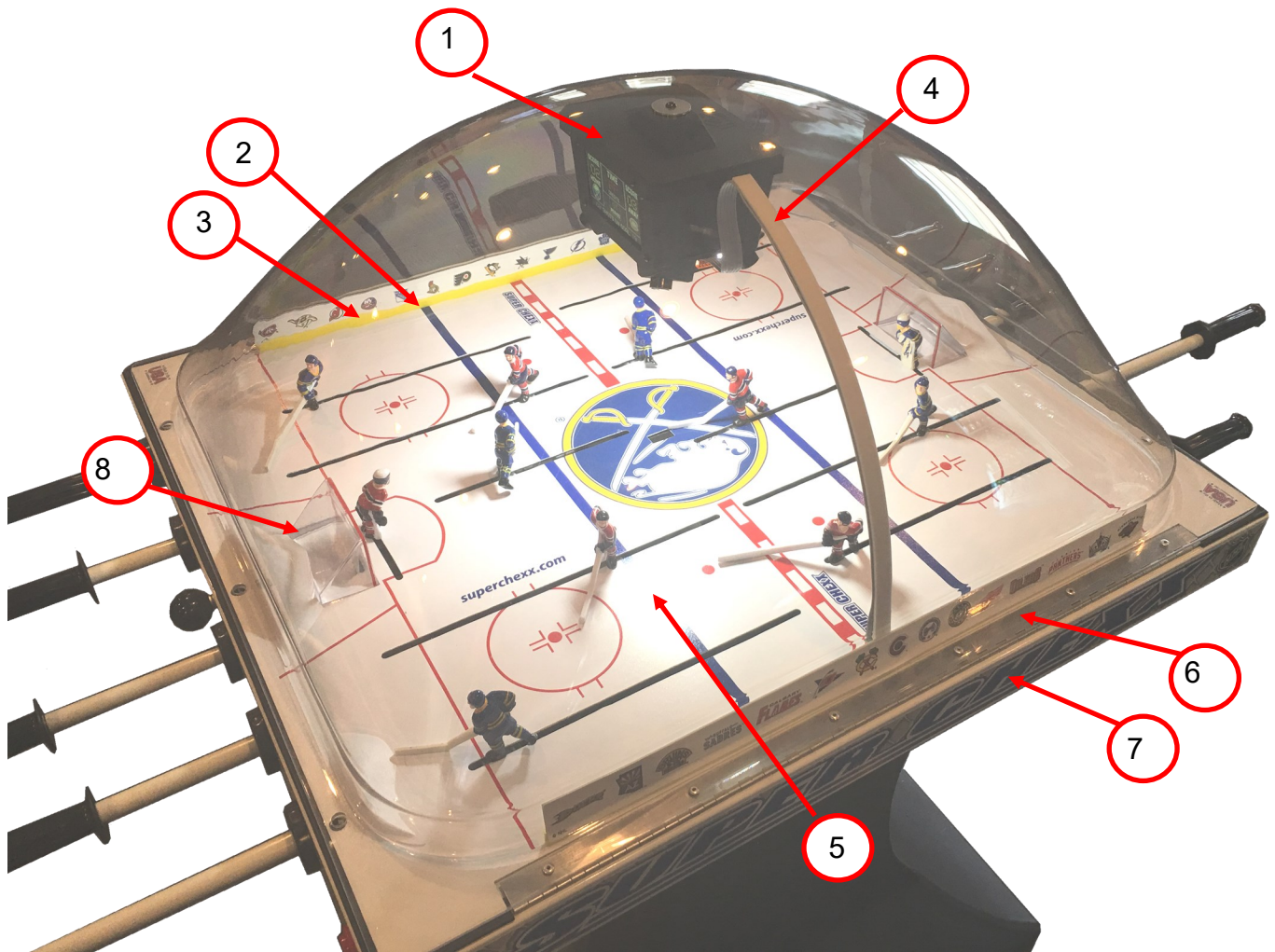

Dome Assemblies

Key #	Part Number	Description
1	SC3128X	Jumbotron
2	SC7024	White Sideboard Decal
3	SC7027	Yellow Sideboard Decal
4	SC2180LX	Ribbon Cable Assembly
5	SC3025ICEX	Ice Surface Assembly
6	SC1016	Dome Hinge
7	SC745	Super Chexx PRO Cabinet Decal
8	SC3002	Chute/Net

SC1000UICEB = CHEXX Set of 6 ICE BLUE TEAM (Not Shown).
 SC1000UICER = CHEXX Set of 6 ICE RED Team (Not Shown).

ROD ASSEMBLIES

QTY:2 Per Game: Medium sticks (Centermen).

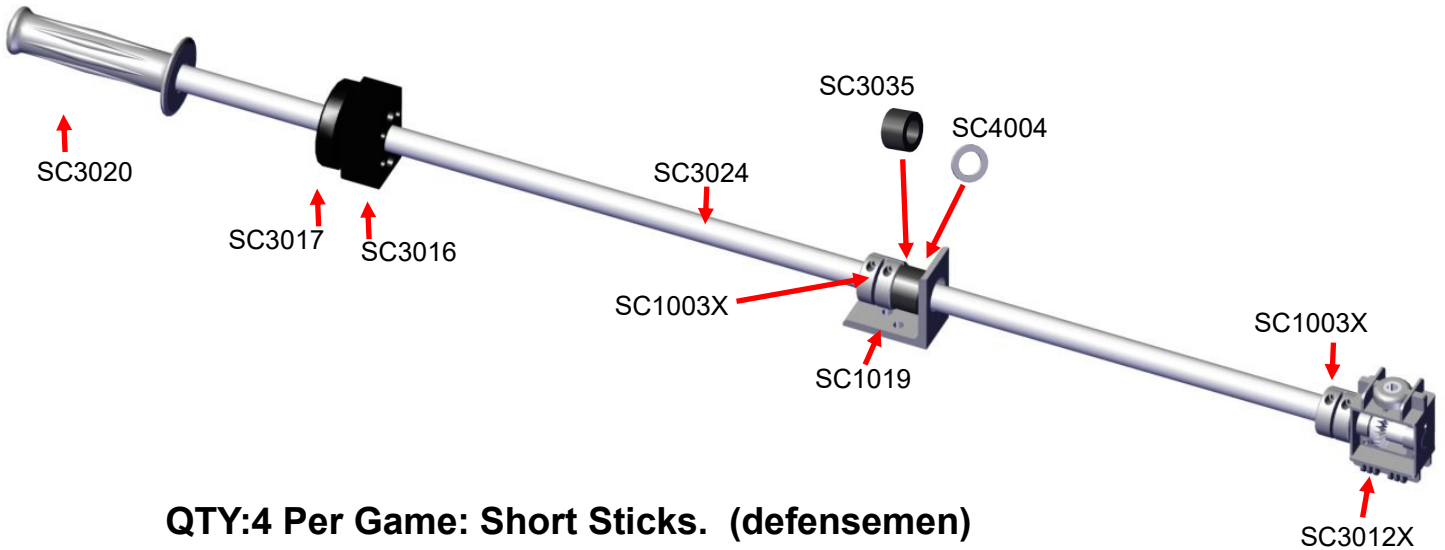

QTY:4 Per Game: Short Sticks. (defensemen)

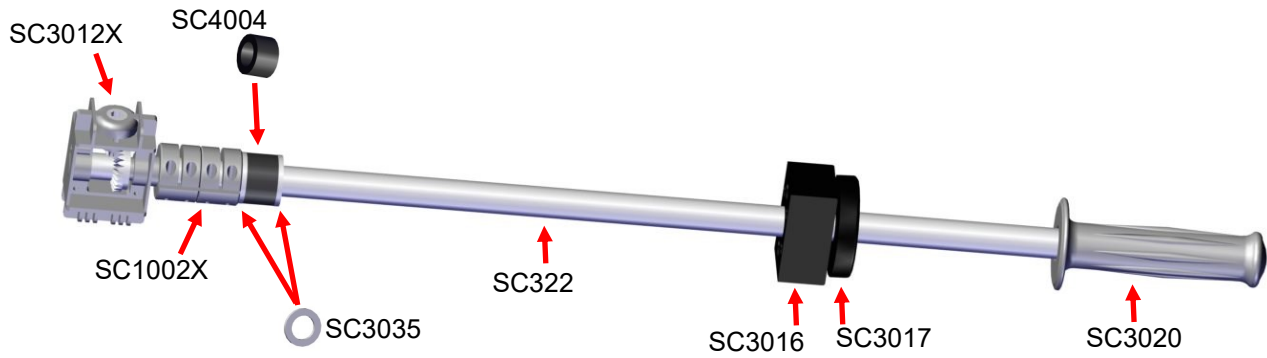

QTY:4 Per Game: Long Sticks. (Wingers).

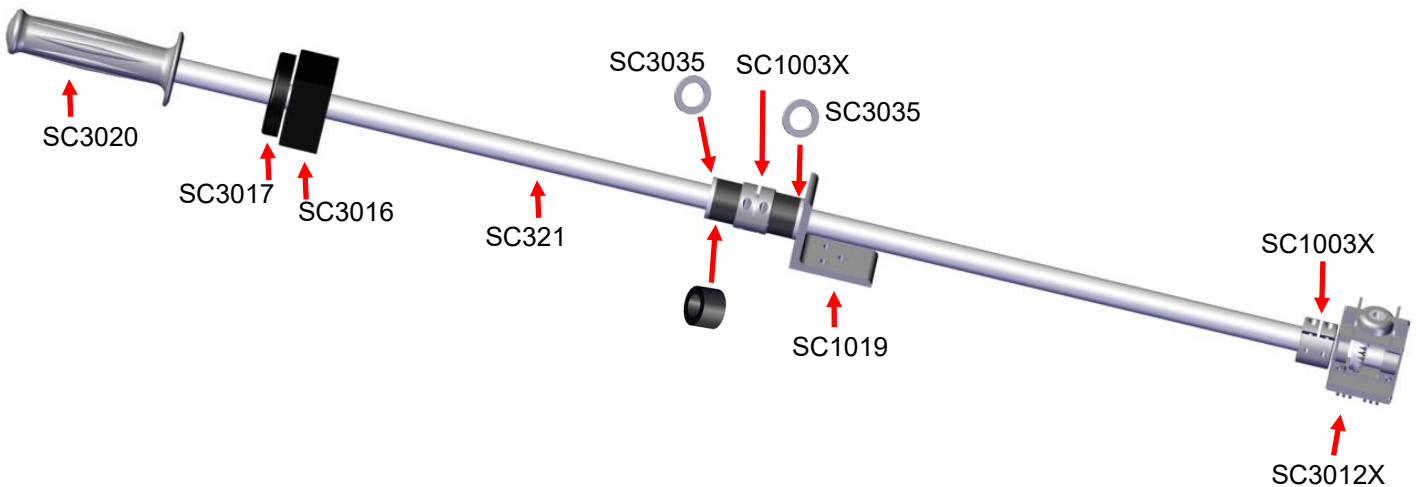

Ejector Assembly

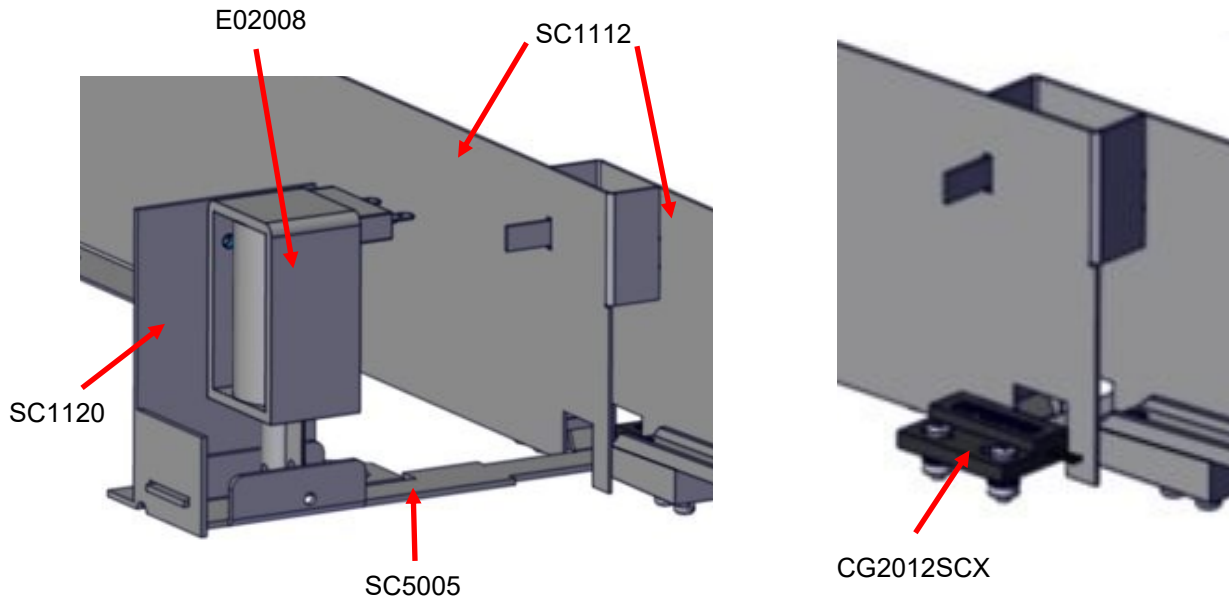

Goalie Assembly (2 per game)

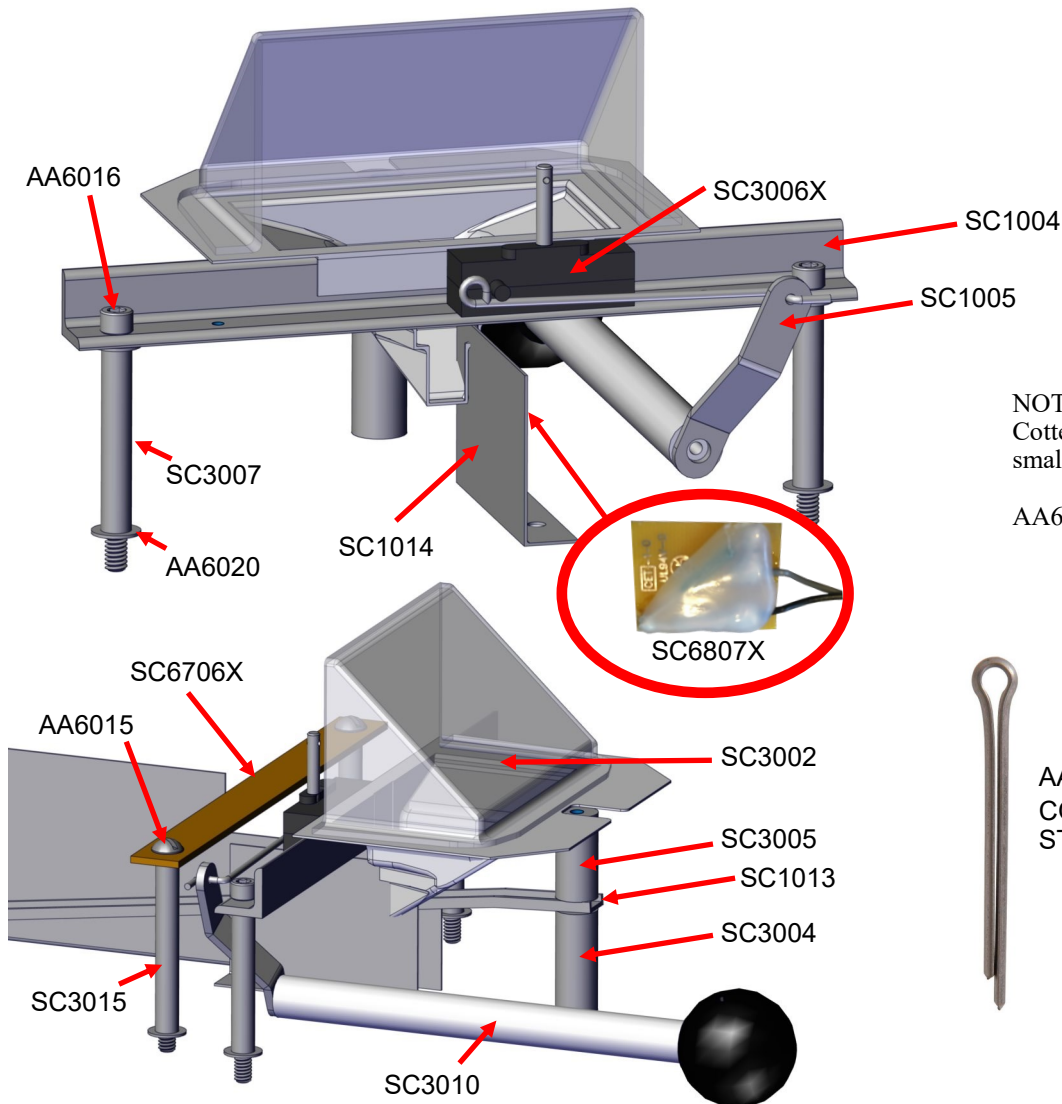

NOTE:
Cotter pin has been replaced by a
small Phillip Screw.

AA6507 - 2-56 x 5/16 PPHMS SS



AA6076
COTTER PIN 1/16 X 3/4
STAINLESS

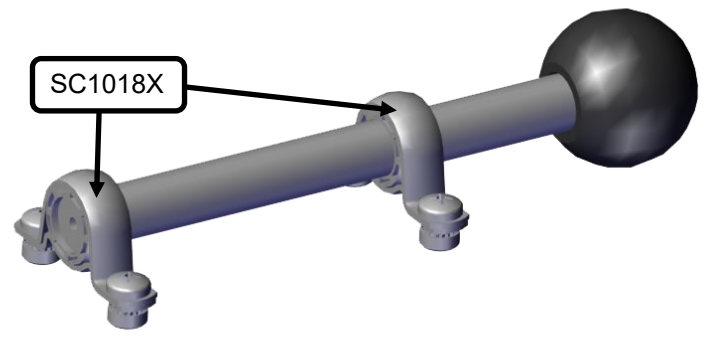
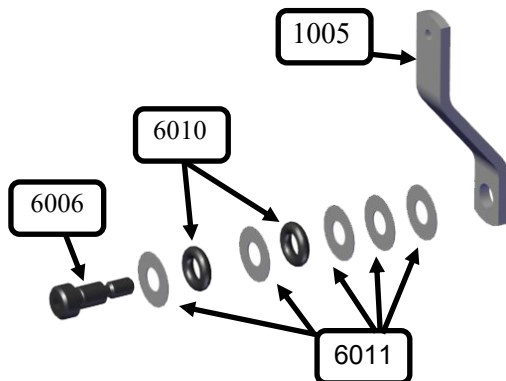
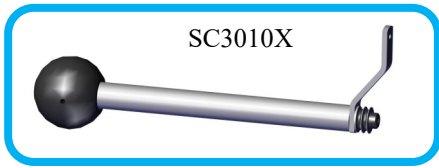

SC3128X Jumbotron Score Assembly

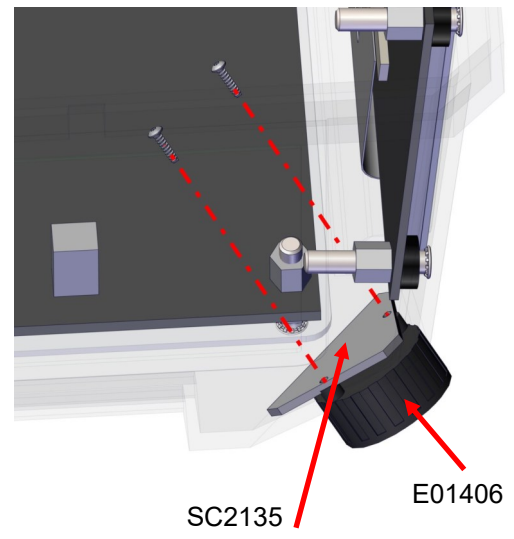
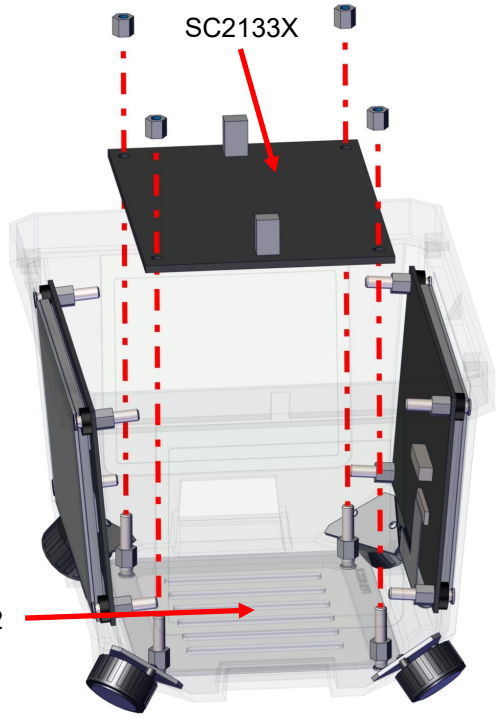
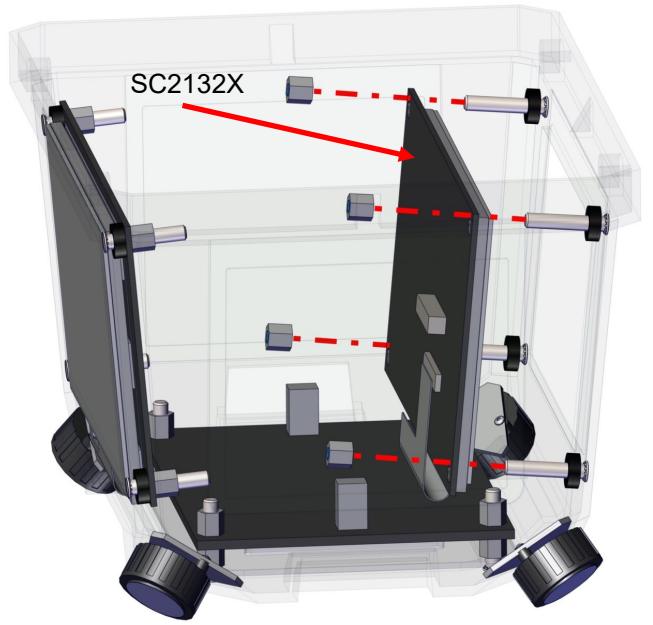
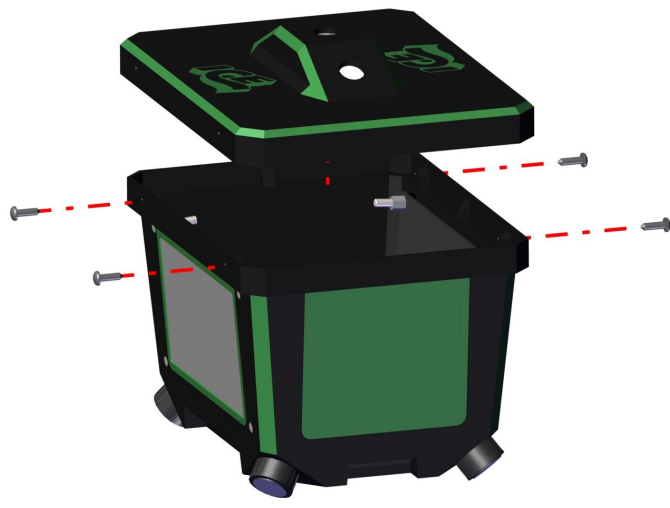

Step 1: LED Light Kit update

It is recommended to locate a box that will accommodate the dome so that you can flip the entire upper part of the game over. The dome should sit inside the box so that the surface will not be scratched when installing the LED kit.

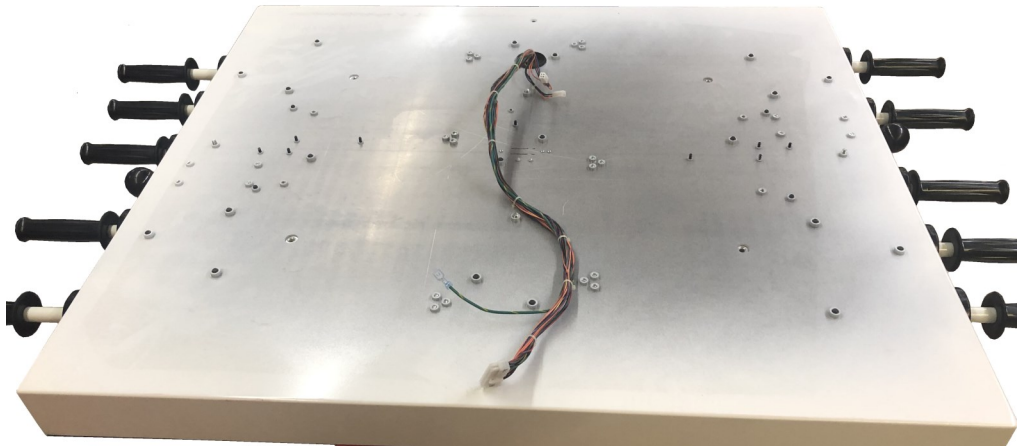

Step 2:

Position the pieces around the edges with the grooves at the top.

Lock the corners as shown.

The sides lock in around the pegs.

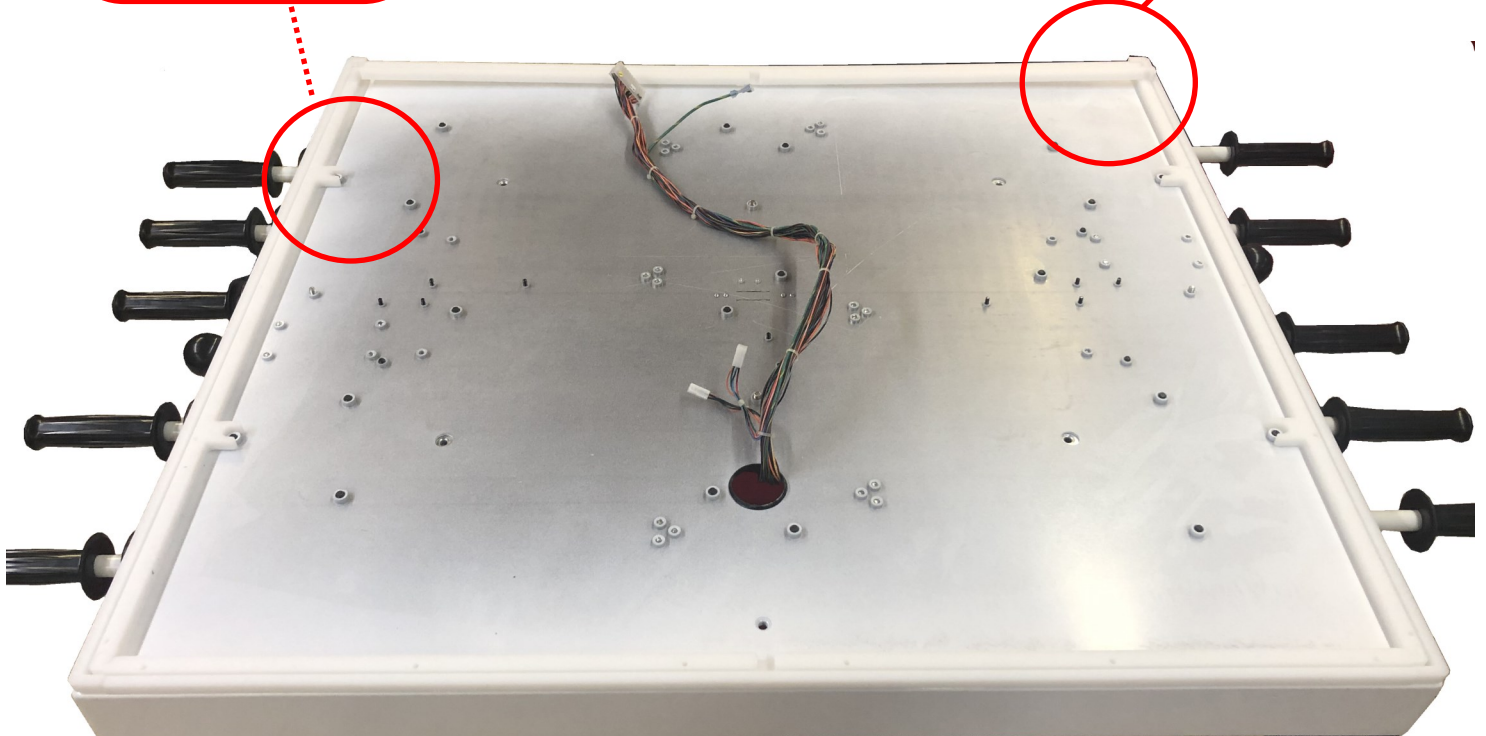

Step 3:

Only on one of the LED strips and at the ends with the wire harness remove a small section as shown below. DO NOT REMOVE MORE THAN THIS. If more is removed, you will not be able to insert the LED strip in the groove.



Step 4:

Wrap the LED strip so that the backside adheres to the plastic and only one LED chip is facing the inside of the channel as shown below. Give the LED a slight push to ensure good adhesion.



Step 5:

Insert the LED strip carefully into the grooves with the LED's facing outward. Continue until you reach the end of the strip.

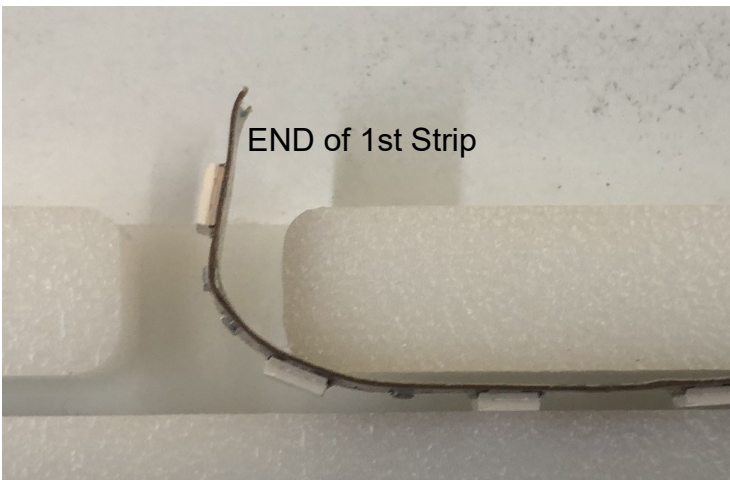

Step 6:

Using masking tape, secure the LED strips from coming out by taping making sure that the tape is not on the outside and visible. It will remain when all is finished.



Step 7:

Remove the backing off the other roll of LED's, attach this to the previous roll.

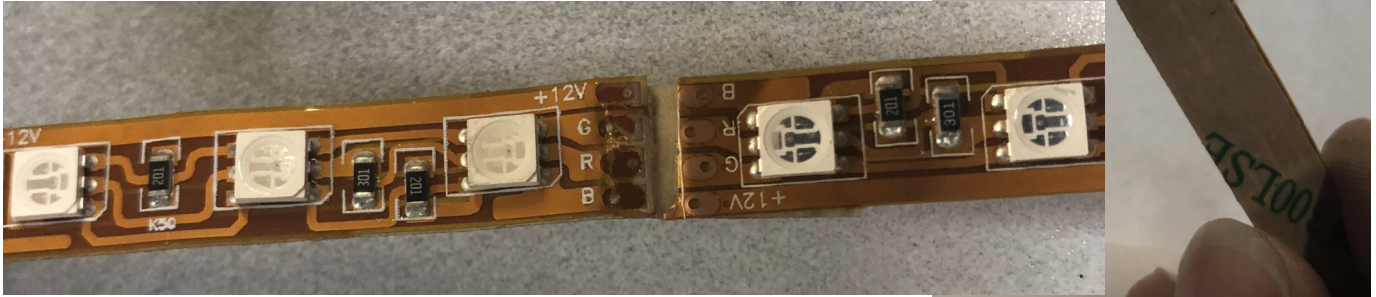

Step 8:

Continue to insert the LED roll all the way around until you reach where you started. Then using masking tape, secure the LED strips.

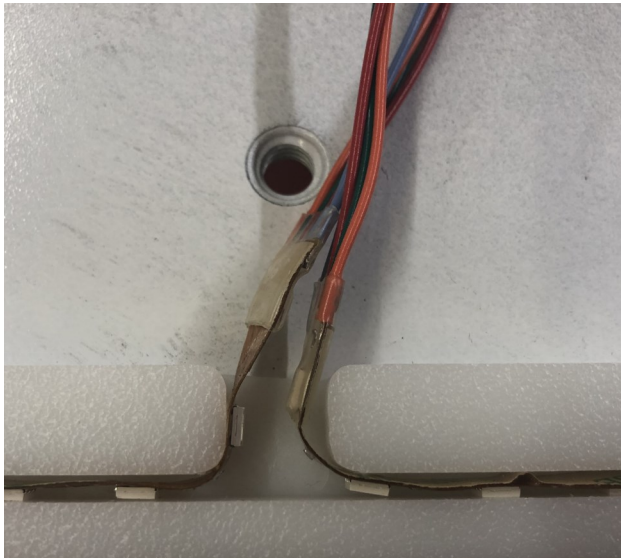

Step 9:

Flip the assemble over. The LED connections should be nearest to where the wires come from the playfield.

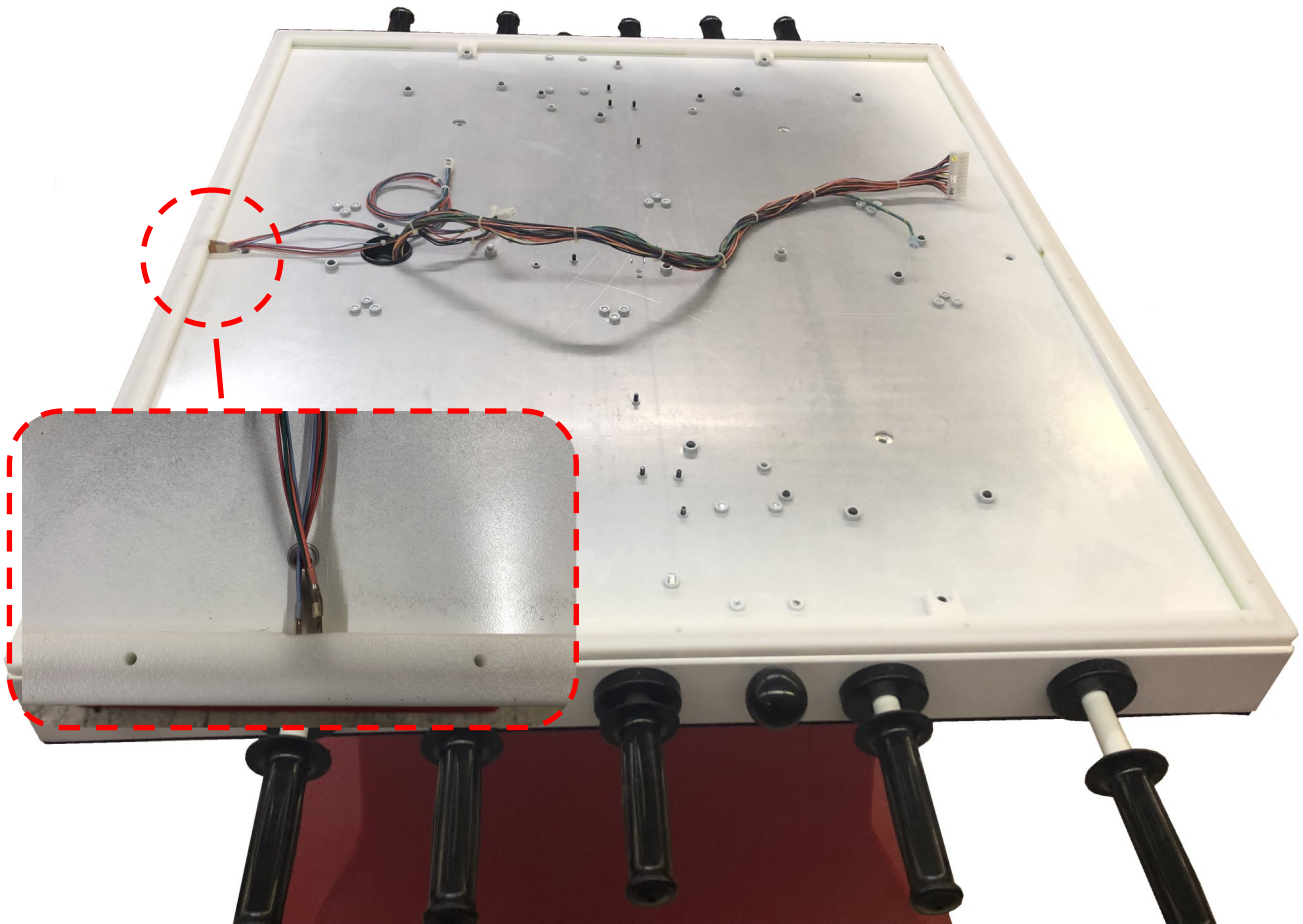

Step 10:

Connect the LED connector to the main harness. The wires will match colors. Then wire tie the wires that are loose.

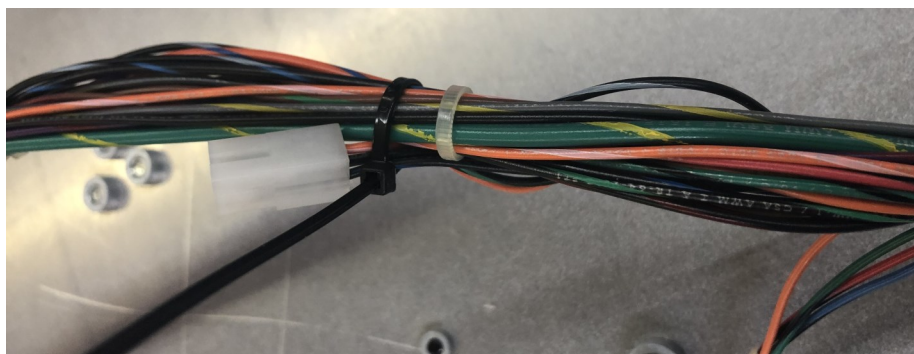
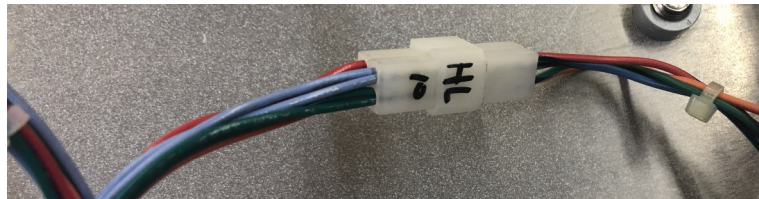

Step 11:

Using the self tapping screws (6681) to attach the LED frame to the game's underside.



Step 12:

Then attach the wire harness connector cover. Be careful of where it is mounted so that the screws do not punch through the wire harness on the other side and they do not end up into the rail cover. Then flip the playfield over and reattach to the game.

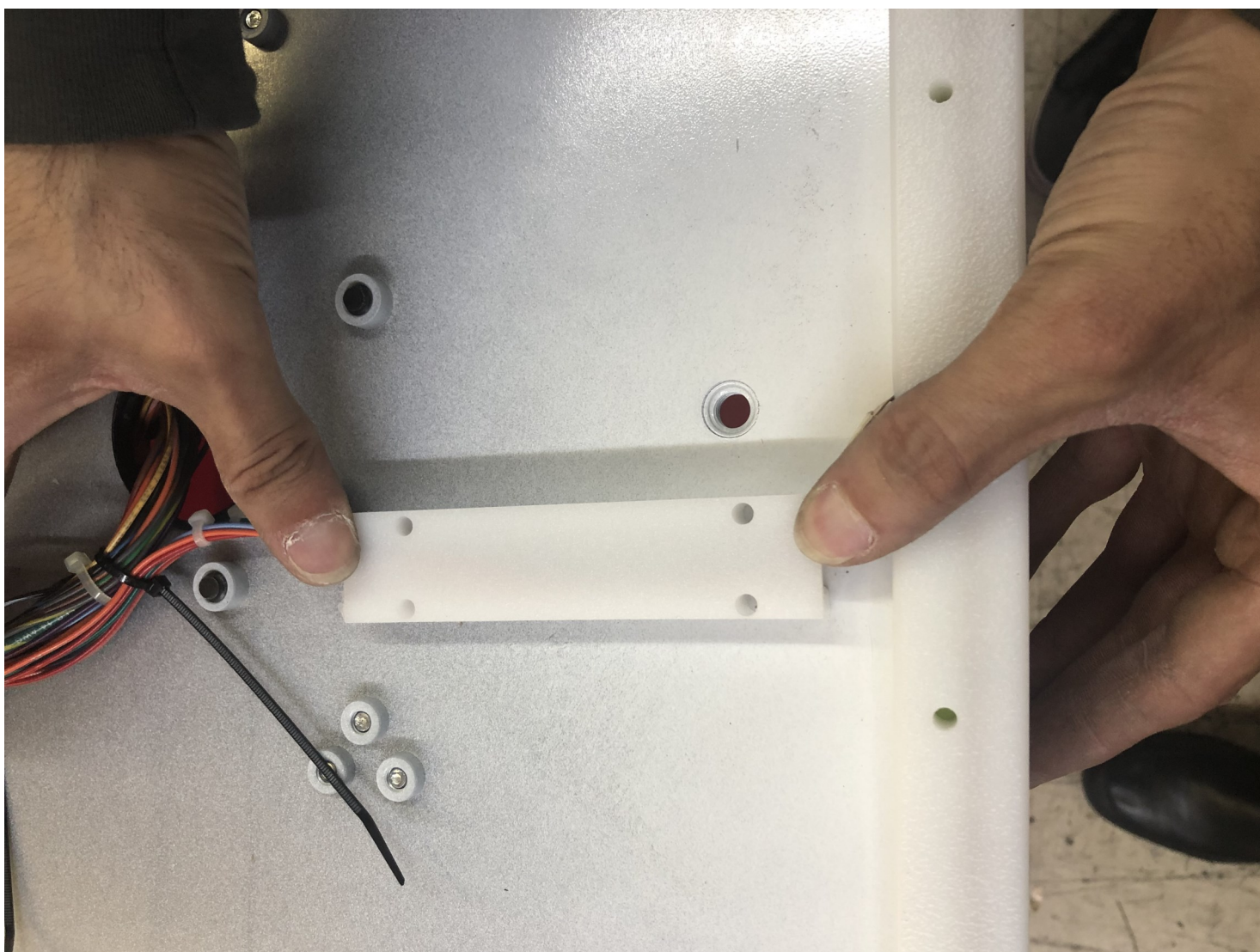



WARRANTY POLICY

I.C.E. Inc warrants all components in your new Super Chexx Pro Home Edition machine to be free of defects in materials and workmanship for the period of ONE YEAR from purchase date. To be a "Home Edition" game it must not contain a coin door or be able to be operated by money.

I.C.E. Inc shall not be obligated to furnish a warranty request under the following conditions:

- The game is operated commercially.
- Equipment has been subjected to unwarranted stress, abuse or neglect.
- Equipment has been damaged as a result of arbitrary repair/modification.

Products will only be covered under warranty by obtaining an I.C.E. authorized RMA #. To obtain an RMA # please provide I.C.E. tech support with the game serial # or original I.C.E. invoice # and a detailed description of the failure or fault symptoms.

All warranty parts needed will be paid in advance before shipping.

I.C.E. Inc will cover domestic UPS ground, or comparable shipping costs during the warranty period.

International or expedited shipments are available for an additional charge.

Defective parts must be returned to I.C.E. Inc, at the customer's expense, within 30 days of shipment. After 60 days no credits will be issued for returned items.

I.C.E. Inc will assume no liability whatsoever for costs associated with labor or travel time to replace defective parts. All defective warranty covered components will be replaced with new or factory refurbished components equal to OEM specifications. I.C.E. Inc will not provide any on-site services to repair the game.

ICE distributors are independent, privately owned and operated. In their judgment, they may sell parts and/or accessories other than those manufactured by I.C.E. Inc. We cannot be responsible for the quality, suitability or safety of any non-I.C.E. part or modification (including labor) that is performed by such a distributor.

